

 Roland

Electronic Guitar

GR-100 OWNER'S MANUAL

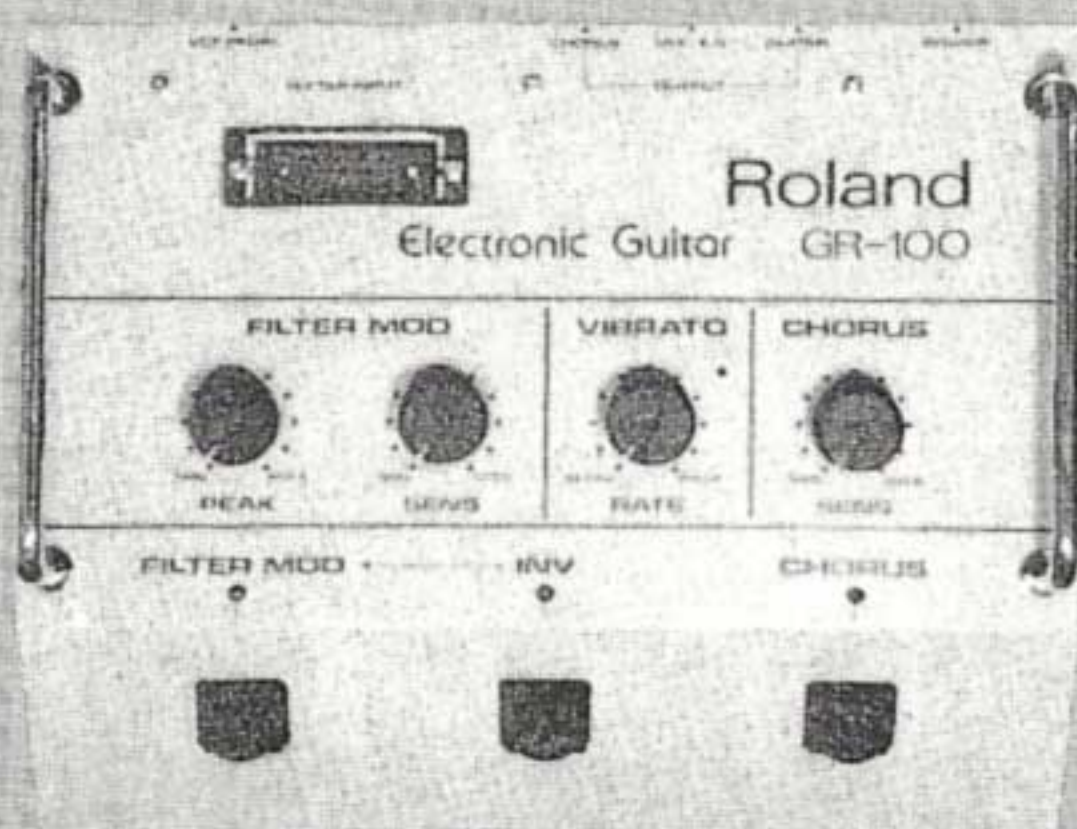

SPECIAL FEATURES

- The GR-100 can produce, by means of a unique electronic circuit, an entirely new electronic sound effect previously not possible with earlier electric guitar models.
- Playing the guitar is fun thanks to the rich tone quality made by the Hexa VCF which uses a VCF for each string.
- A wide range of electronic sounds are possible from the filter modulation, touch vibrato and chorus effect.

< Before Playing >

- Plug in the power cable. Connect the guitar, and then turn the power switch ON.

« Caution »

- GR-100 is to be used with a guitar controller (G-202, 303, 505, 808). GS-500 should not be used.
- When not in use for any lengthy period of time, please unplug the power cable.
- Do not place or drop any heavy object on either the power cable or connection cables as they are likely to be damaged.
- Neon lights, fluorescence lights, etc. near the main unit, the guitar and the amplifier may cause noises. If so, please change your position.
- Please avoid hot, humid or dusty places as they may cause breakdowns.
- Use good synthetic detergent to clean the panel section.

GUITAR CONNECTION

● Connection with G-202, 303, 505, or 808

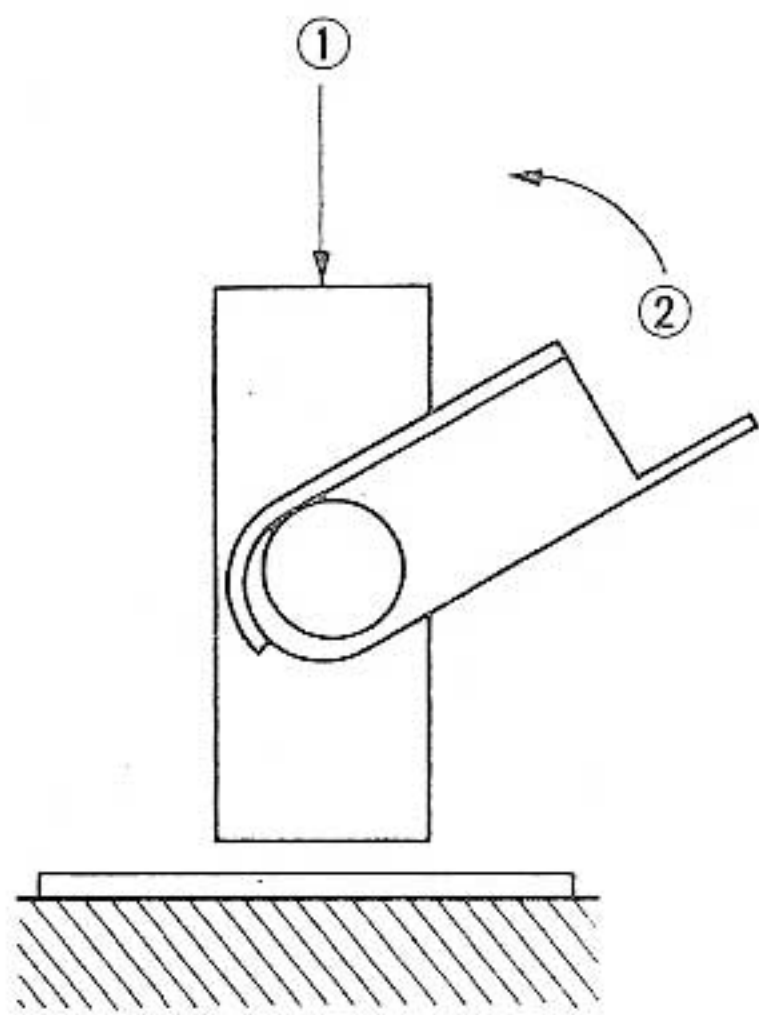
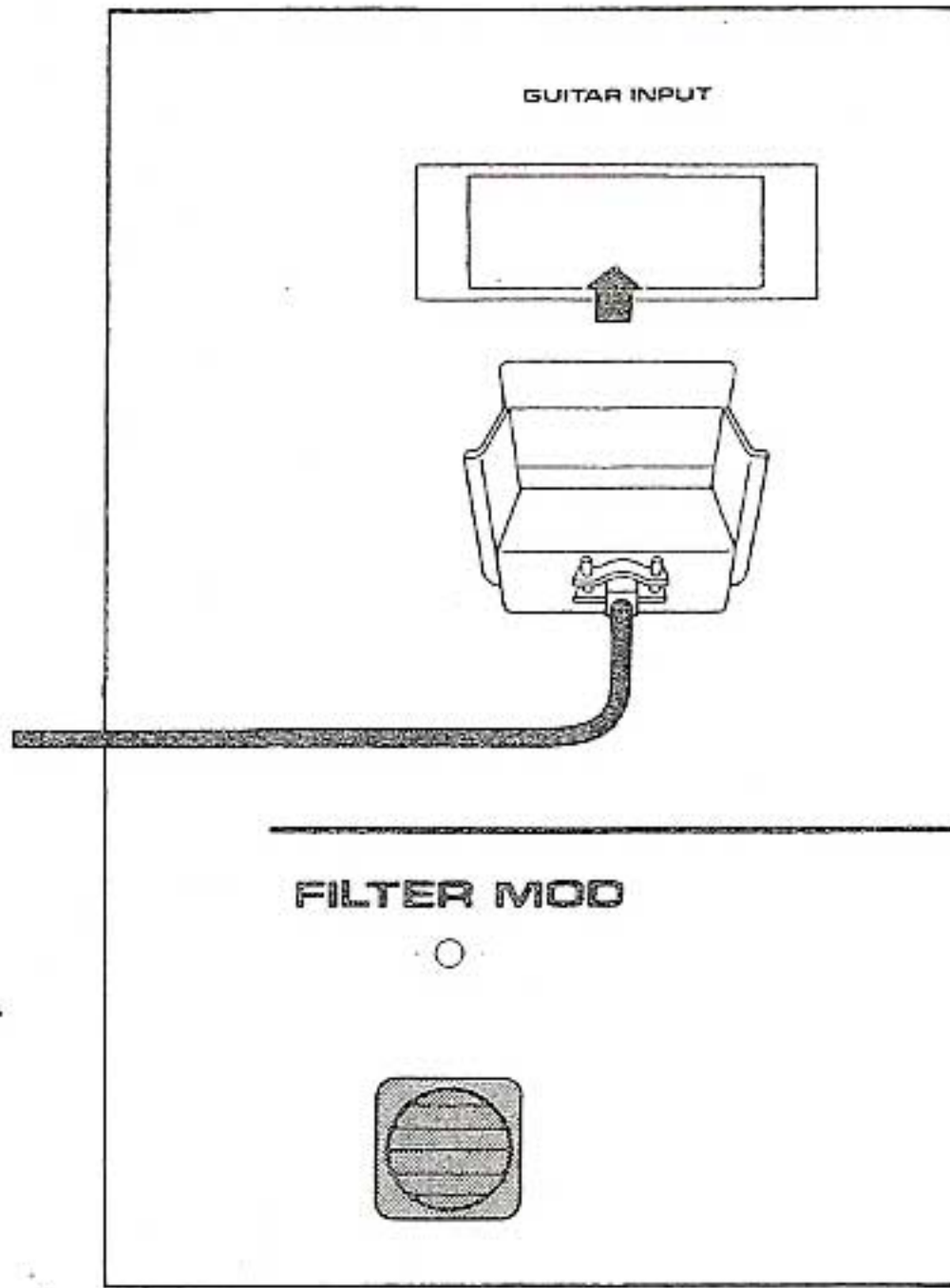

AMPLIFIER CONNECTIONS

● One Amplifier

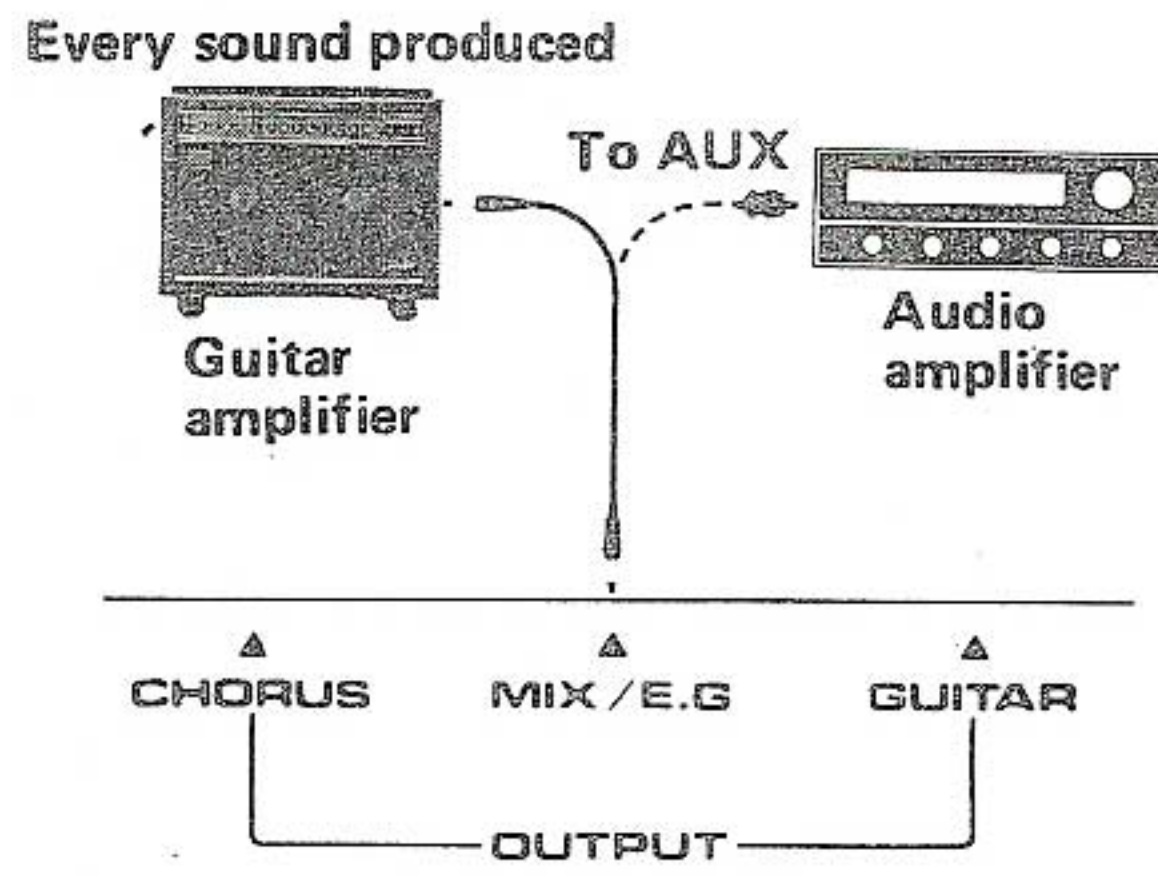

● Two Amplifier (Chorus, Vibrato ON)

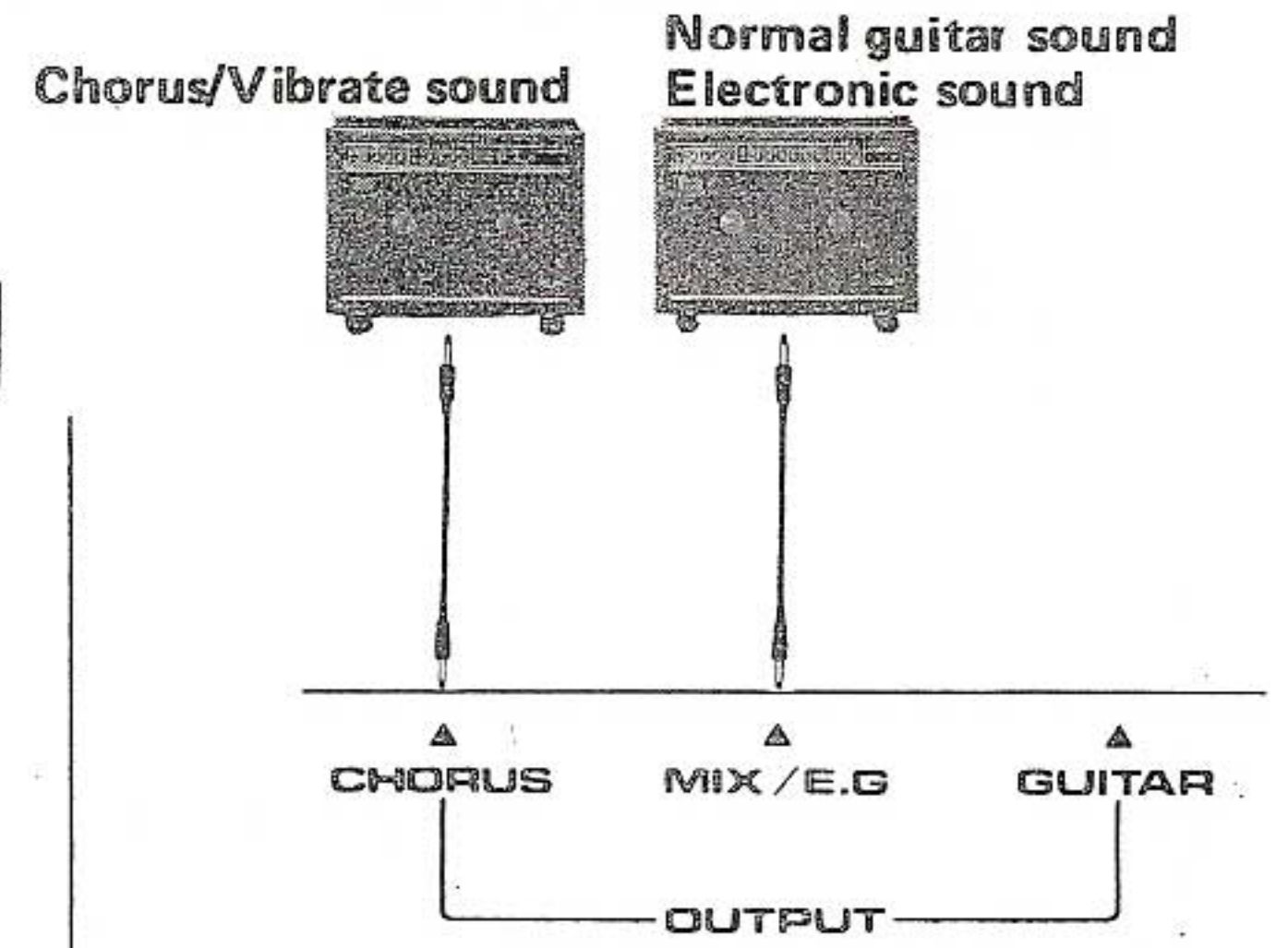

● Two Amplifiers

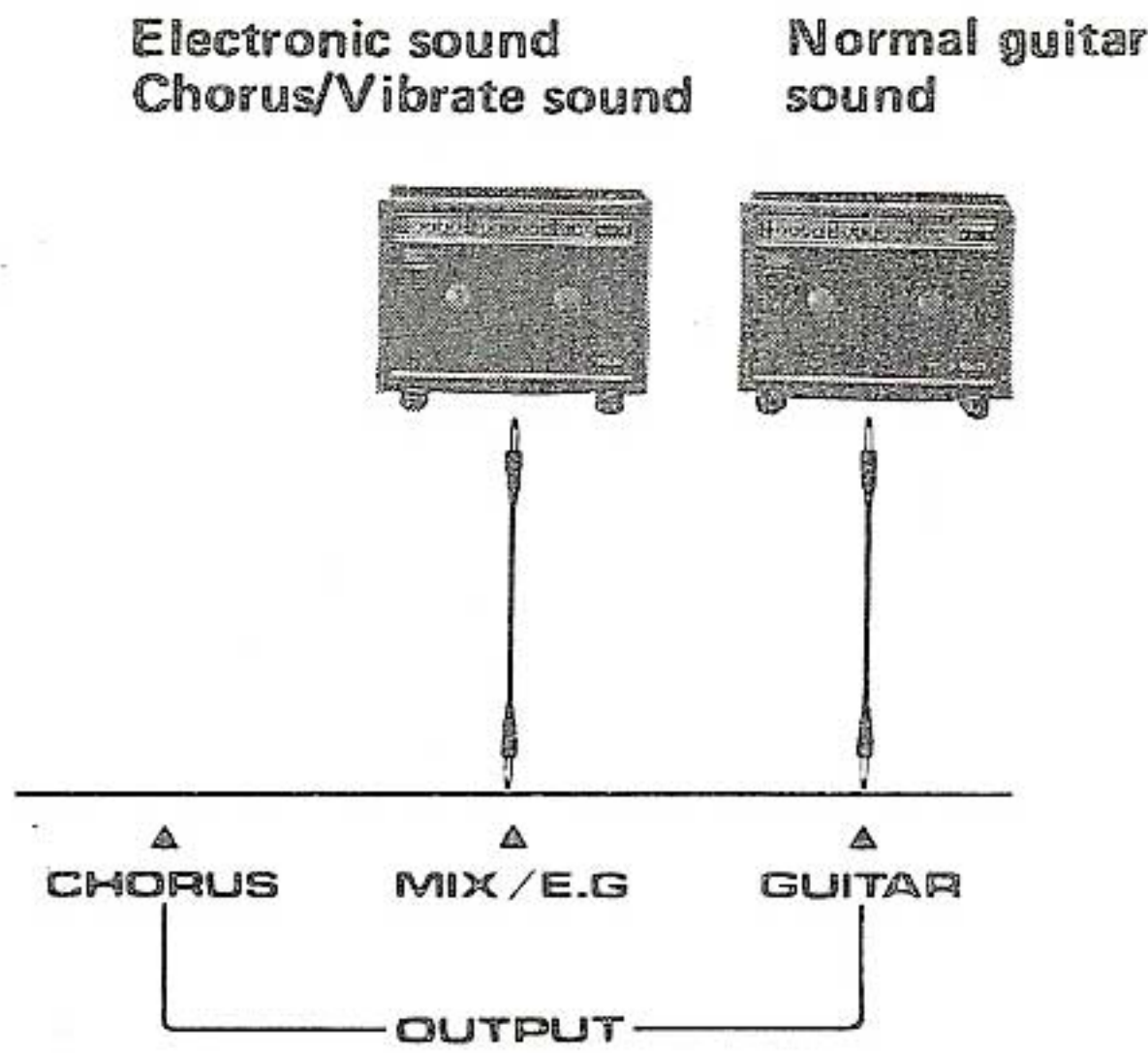

● Three Amplifiers

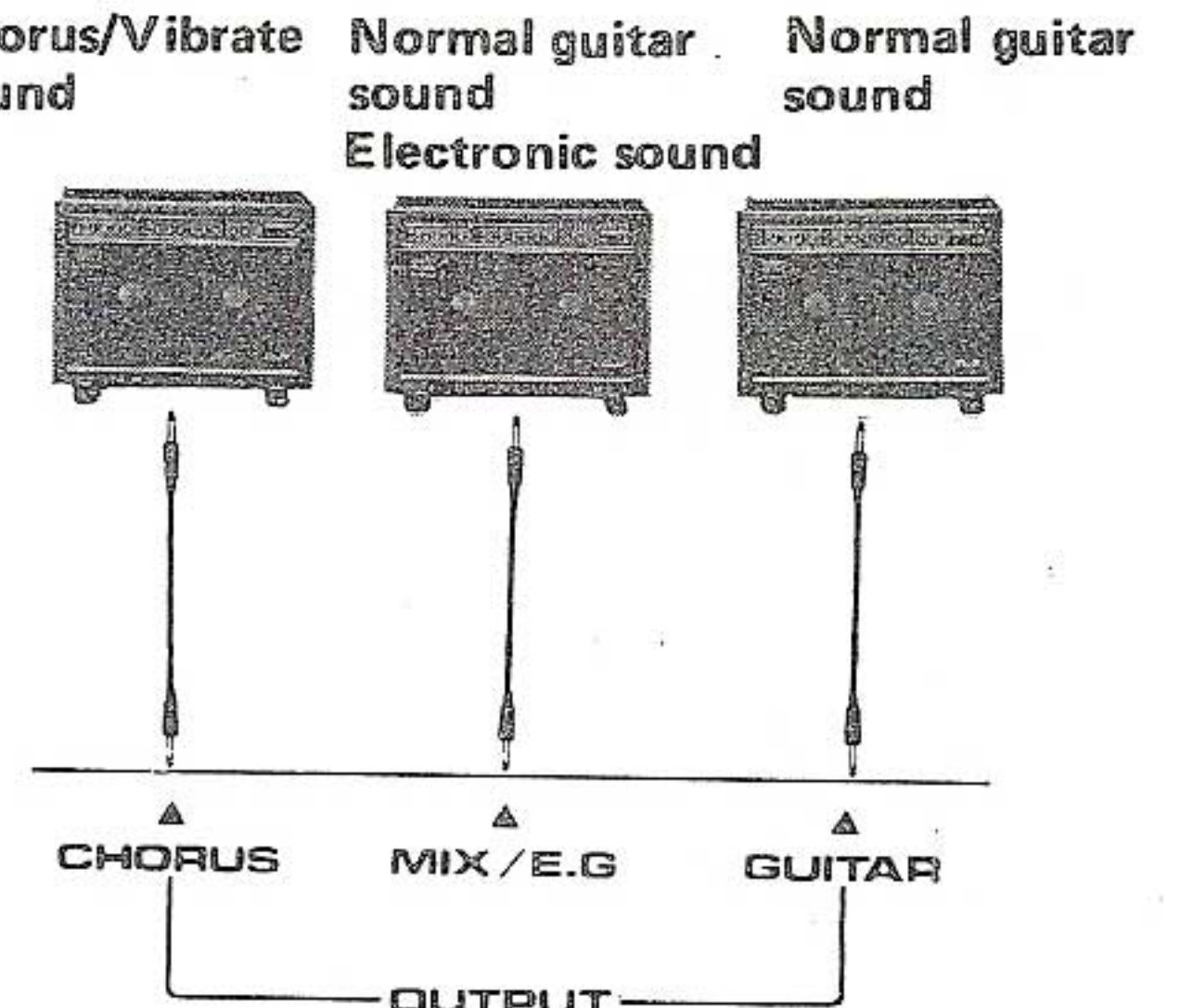

* To turn the GR-100's source switch on for guitar amplification, put the guitar and guitar amplifier volume at "0" and then switch to ON.

SOUND CONTROLS FROM THE GUITAR

* The lower line knob switch is on the guitar.

● Basic Setting

GR-100

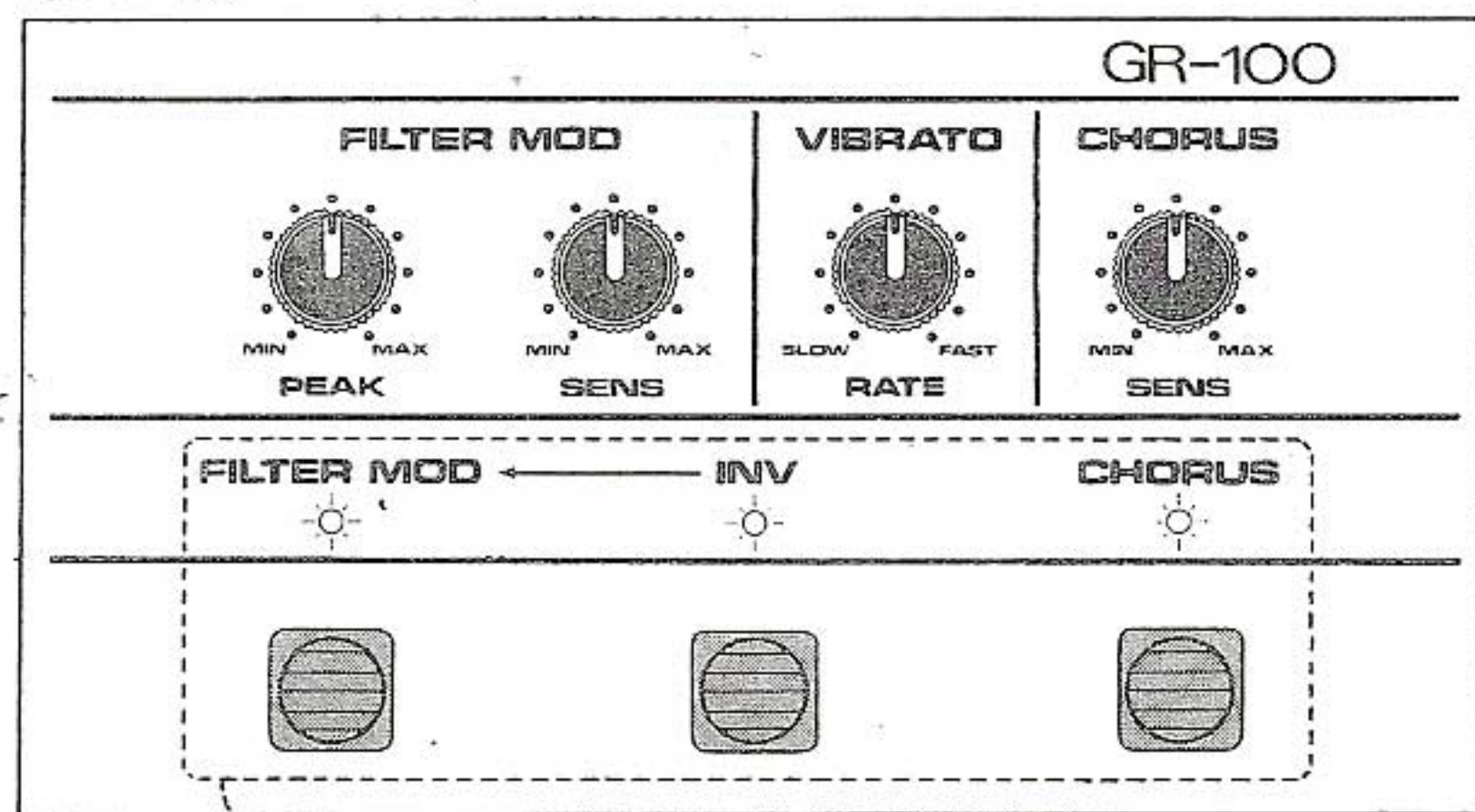

Press the foot switch for flickering (OFF).

GUITAR

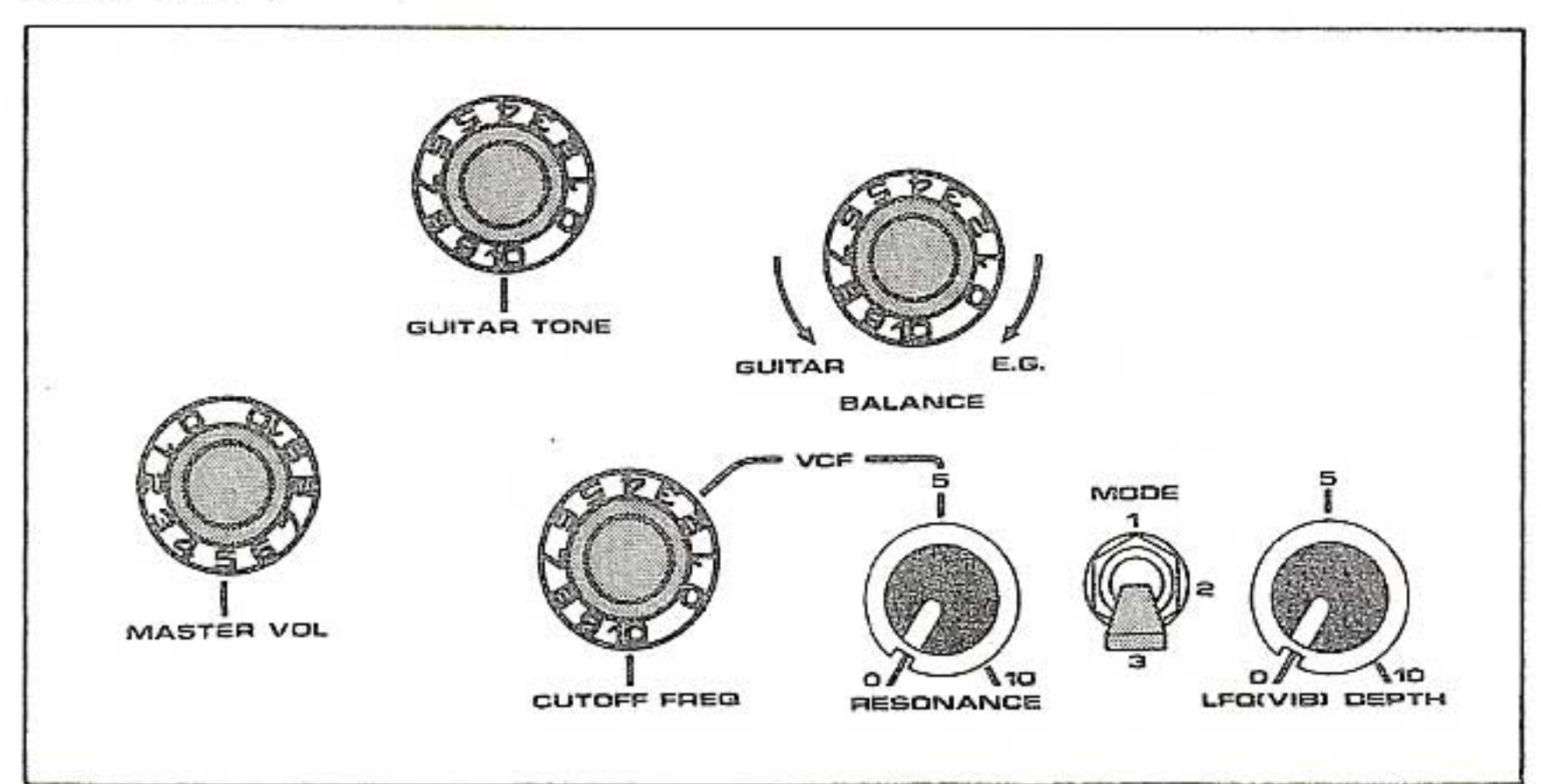

■ Mode Selector

* With the mode selector for models G-303 and 808, DIST = 1, DIST/VCO = 2 and VCO = 3.

■ Balance Control

● When the mode selector is set at 1, a normal sound is produced when the guitar is played.

● When the mode selector is set at 2, a stacatto electronic sound is produced when the guitar is played.

● When the mode selector is set at 3, a sustained electronic sound is produced.

■ Balance control

The electronic sound is mixed by turning the balance control to the right (clockwise). At position 10, only electronic sound is produced. At position 1, only normal guitar sound is produced. (The same situation as when the mode selector is set at 1.)

* With the mode selector set at position 1 (DIST), the effect of the balance control is neutralized and only normal guitar sound is produced.

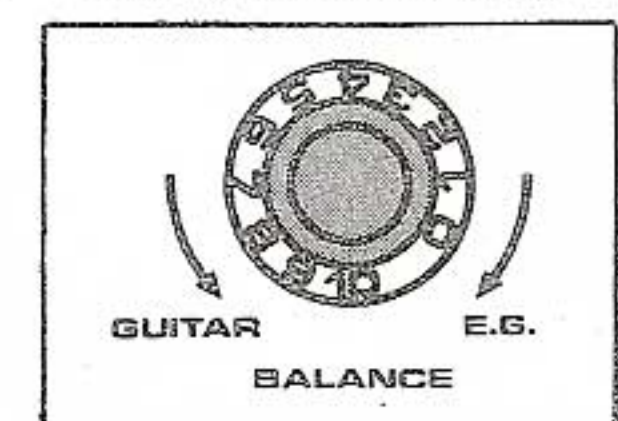
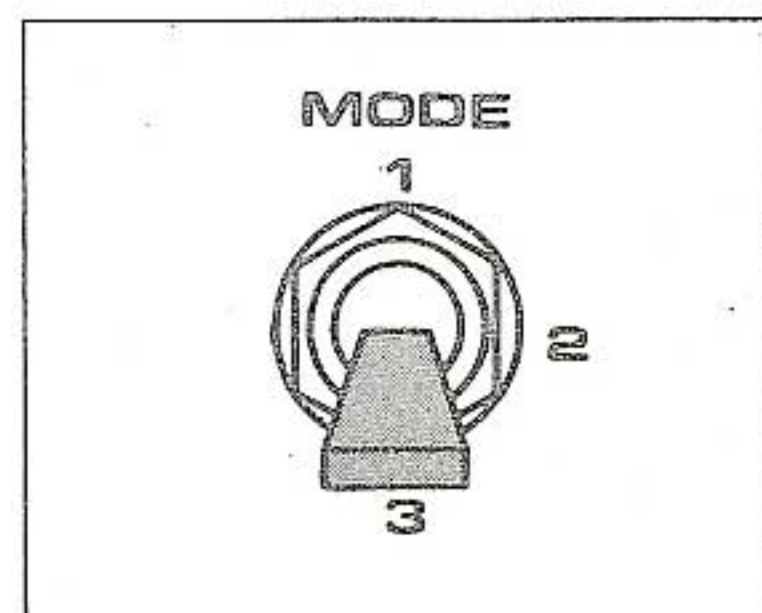
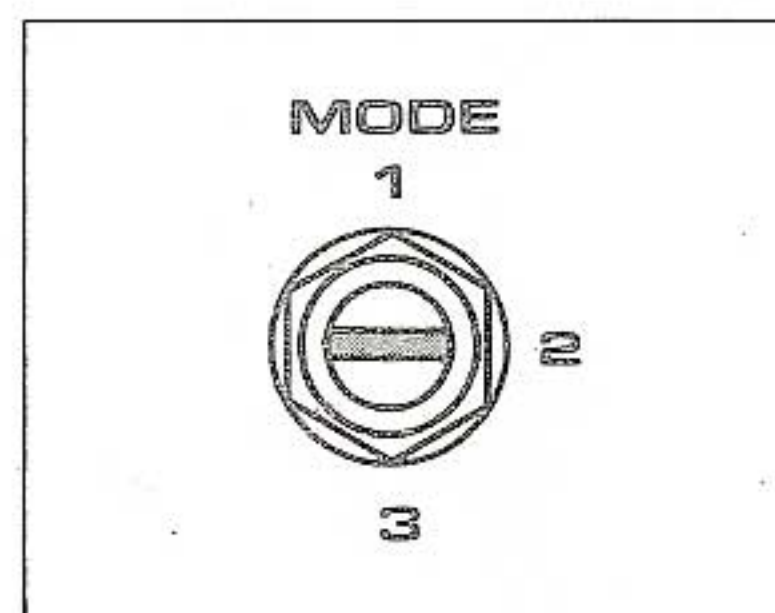
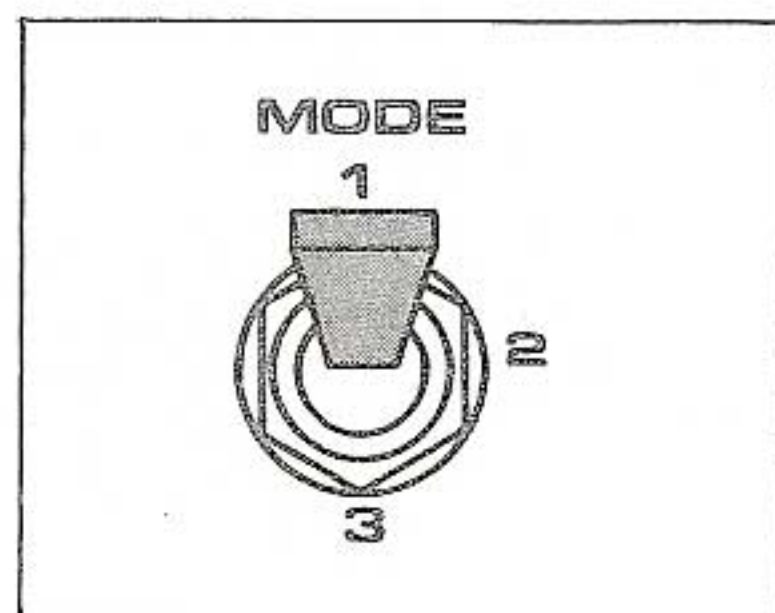

★ THE CUT-OFF FREQUENCY AND RESONANCE OF THE ELECTRONIC SOUND TONE CAN BE CONTROLLED.

■ Cut-off Frequency

By turning the control from position 10 to 0, high frequency ranges are progressively removed. While the sound quality becomes softer, the sound volume also diminishes.

● Let's try to create some different kinds of sounds.

While setting the resonance at 0, 5, and 10 in sequence, gradually turn the cut-off frequency control from 0 to 10 at each position to verify changes in sound quality.

1. Resonance "0"

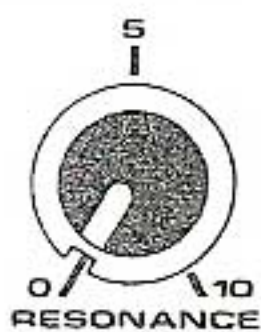

A natural electronic sound is produced due to the lack of resonance effect.

2. Resonance "5"

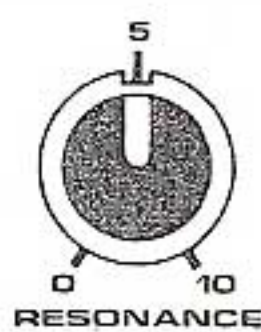

When the cut-off frequency is at a level of position 0-2, the sound resembles that of wind instruments but by raising the cut-off frequency the sound becomes one like a lead guitar used for hard rock music. Picking harmonics are also easy to produce.

3. Resonance "10"

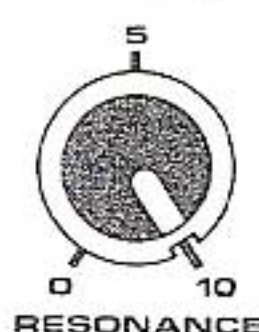

The feedback mechanism is easily produced by effective use of the cut-off frequency control.

* Feedback mechanism

- ① Set the amplifier volume on loud.
- ② Set the resonance to 10.
- ③ Adjust the cut-off frequency to a level of sound which permits feedback.
- ④ When the guitar is played, each sound will produce a long, sustained feedback.

By connecting the foot pedal FV-20 (an optional accessory) to the VCF pedal jack on the A panel, the cut-off frequency can be controlled by using the pedal.

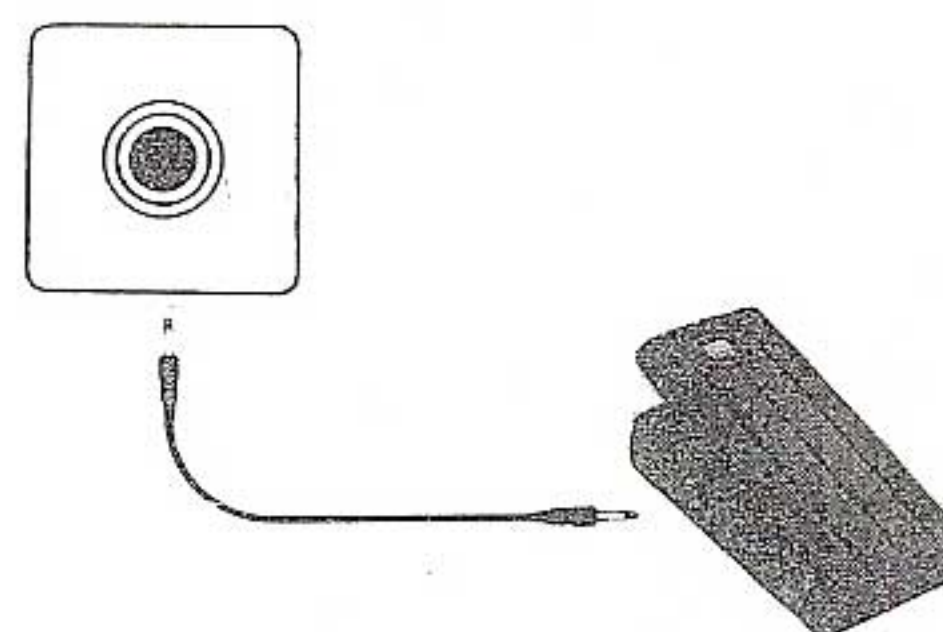

The sound can be controlled for the GR-100 by 6 VCFs (Hexa VCF) which use a VCF for each string.

For example, when the cut-off frequency is closed, the sixth string is open and the sound volume balance has a high fret on the first string, sound separation between each string is made. This is an effect which formerly could not be produced by electric guitars.

■ Filter Modulation

It is possible to give the wah-wah effect to the electronic sound independently of Cut-off Frequency and Resonance. The wah-wah effect can be controlled by picking the guitar strongly or softly.

- ③ Turn the PEAK knob for effect control.

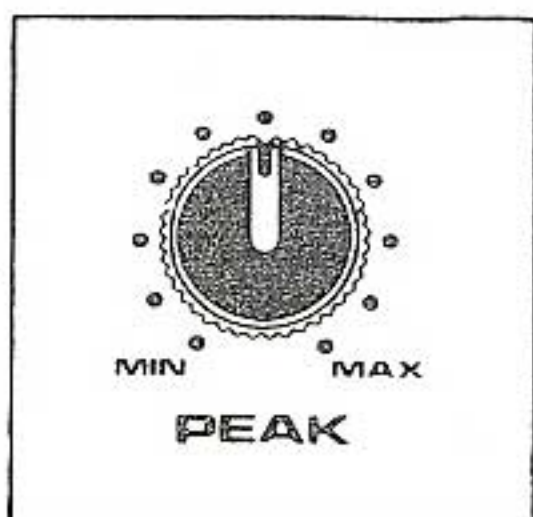

Peak The depth of the wah-wah effect can be adjusted with this. By turning the control to the right (clockwise), the wah-wah effect is made deeper. By turning the control to the left (counter-clockwise), the effect is muted.

■ Touch Vibrato

When playing the guitar, the GR-100 will naturally produce a vibrato effect. But an electronic vibrato effect can also be made.

- ① By turning the Vibrato Depth to the right (clockwise) the depth of effect is controlled.

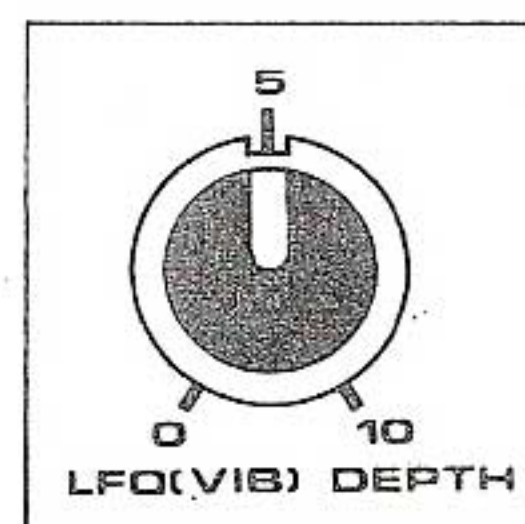

- ② While pressing a string with your left hand, feel the Touch Plate (A) with your right.

- ① Turn the foot switch ON (indicator will be on).

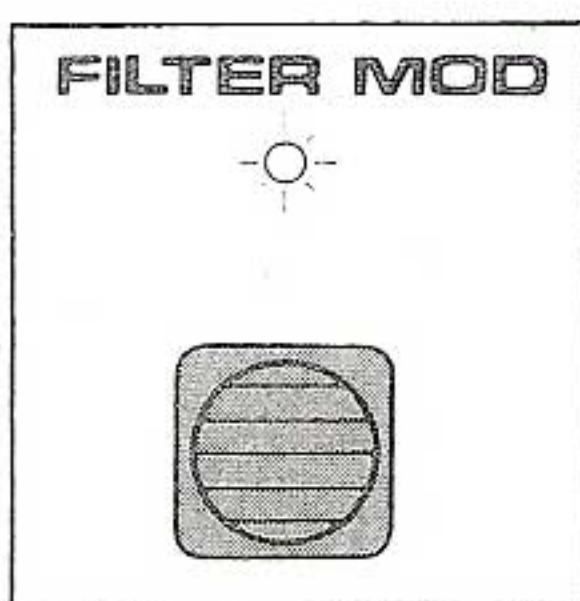

- ② Turn the SENS knob for control.

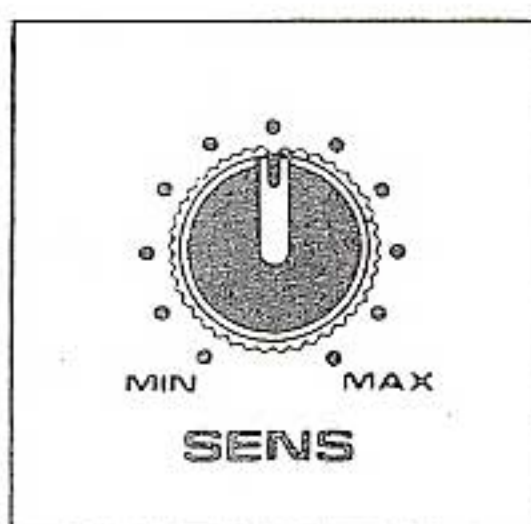

Sens The sensitivity of the wah-wah effect can be adjusted in response to the strength of the picking with this control. By turning it to the right (clockwise), even soft picking can be used for the wah-wah effect. By turning it to the left (counter-clockwise), if the picking is not very strong the effect will not be produced.

■ Filter Modulation Inverter

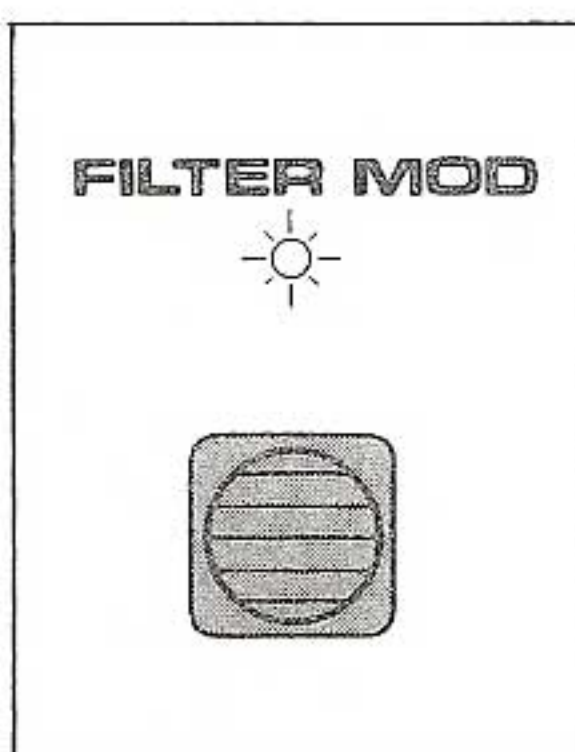

With the foot switch ON, the wahwah effect changes to an opposite sound quality.

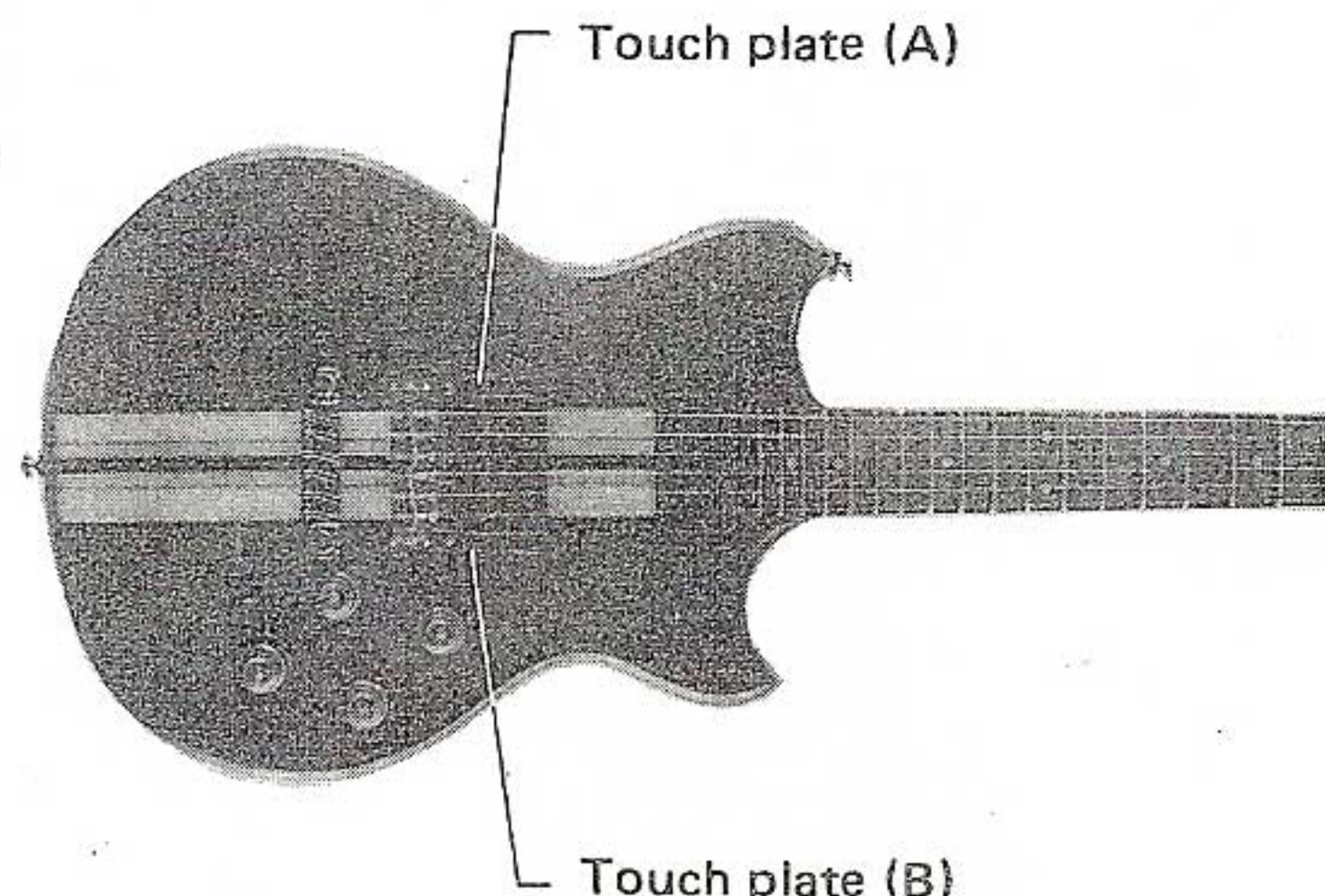

- ③ By turning the vibrato rate control to the right (clockwise), the speed of the effect is adjusted.

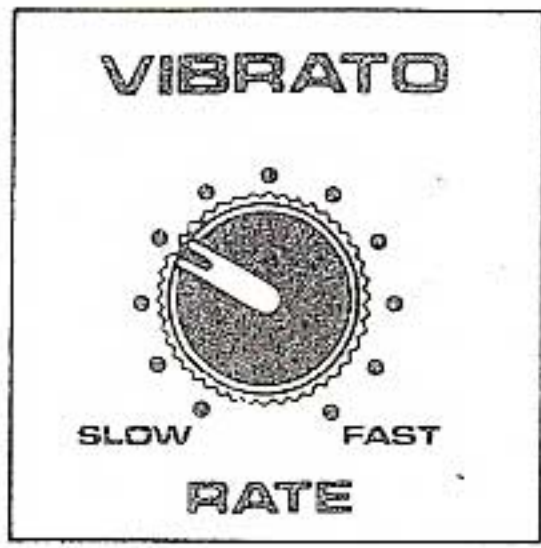

Vibrato indicator

When the vibrato effect is ON, this indicates the speed of the vibrato effect.

*No effect is produced if the Vibrato Depth control is on 0.

★About the Touch Plate

■The Vibrato's ON/OFF Control

●ON/OFF for the continuous vibrato effect

When the touch plate (A) is touched, the vibrato effect is turned ON. When the touch plate (B) is touched, the effect is turned OFF.

●Turning the vibrato effect ON and OFF at once during a performance

When the direct touch plate (B) is touched, the vibrato effect is turned ON. It is only ON while the plate is touched. When your hand is removed from contact with the plate, the effect is turned OFF.

■Chorus

- ① Turn the foot switch ON (indicator will be on.)

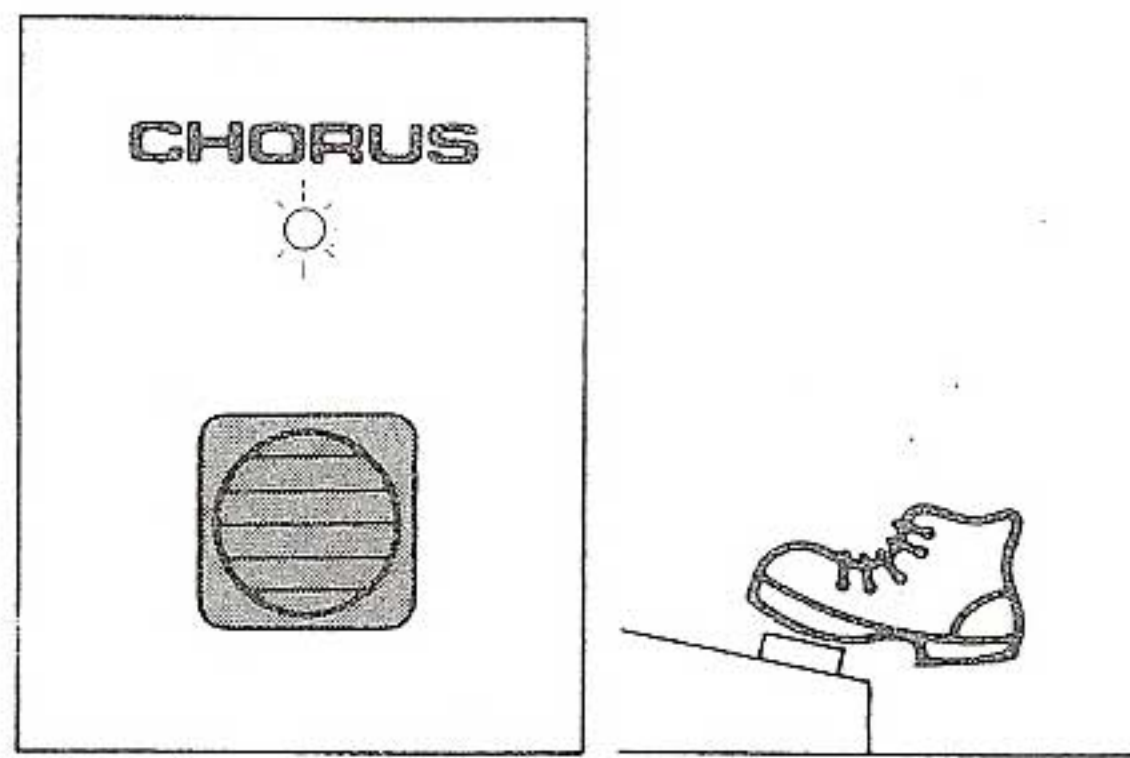

- ② Turn the SENSE knob for effect control.

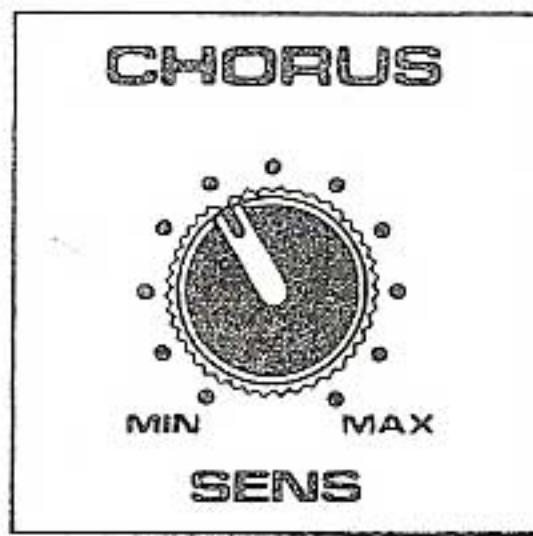

●Chorus/Vibrato

When the chorus effect is ON, if the vibrato effect is then turned on, it automatically cancels the chorus effect and only the vibrato effect occurs. When the vibrato effect is then turned OFF, the chorus effect is again activated.

*It is more effective to use a stereo connection with more than two amplifiers. (Consult the "Amplifier connections".)

MAIN SPECIFICATIONS

Electronic Guitar Control Switch and LED

Filter Modulation

- Peak
- Sense

Vibrato

Rate 0.7 – 8 Hz (LED)

Chorus

Sens

Foot Switch (LED)

- Filter modulation (ON/OFF)
- Filter modulation inverter (NOR/INV)
- Chorus (ON/OFF)

Connection Terminal

IN & OUT ports

- Input: 24 pin connector
- Output: guitar, mix, chorus

REMOTE

VCF pedal (FV-20)

Power Consumption

9W

External Dimensions

300(W) x 250(D) x 93(H)mm

Weight

3.1 kg

Attachment

- 24 pin connecting cord
- Pin jack cord x 1

OPTIONS



Foot volume control FV-20

Carring case SC-1

● Percussive wow

▼GR-100

*Percussive play

▼GUITAR

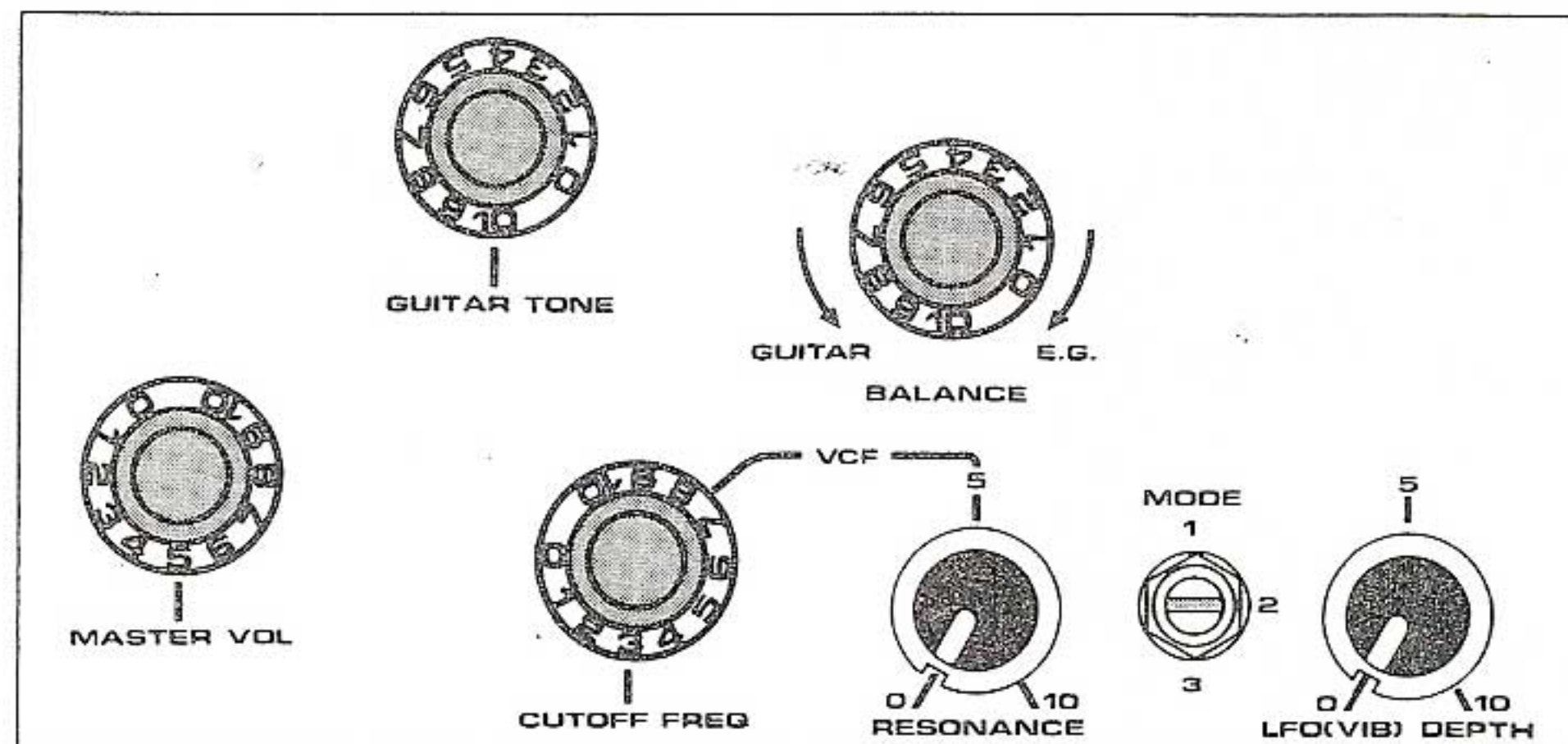
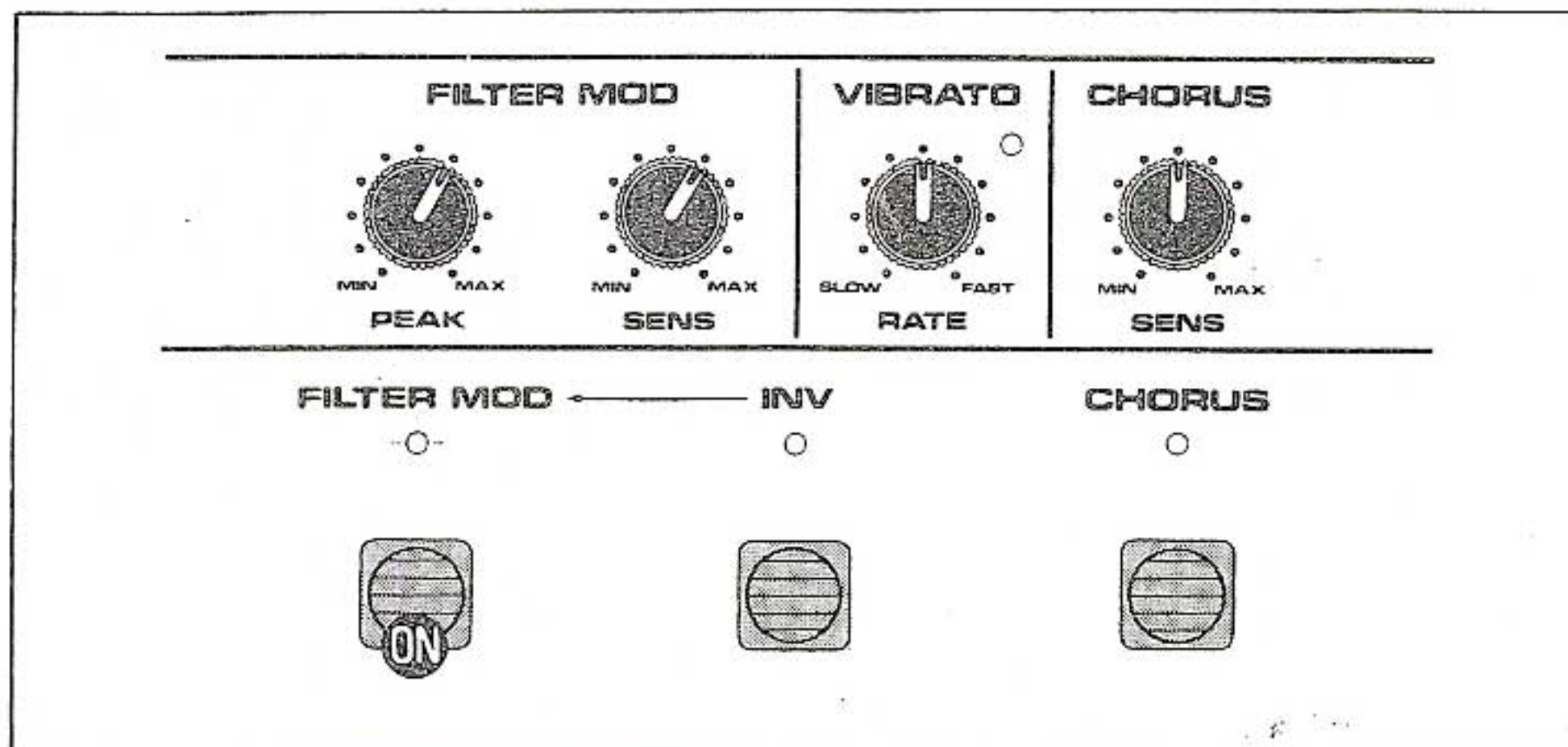

● Metallic chime chord

▼GR-100

*Using touch vibrato

▼GUITAR

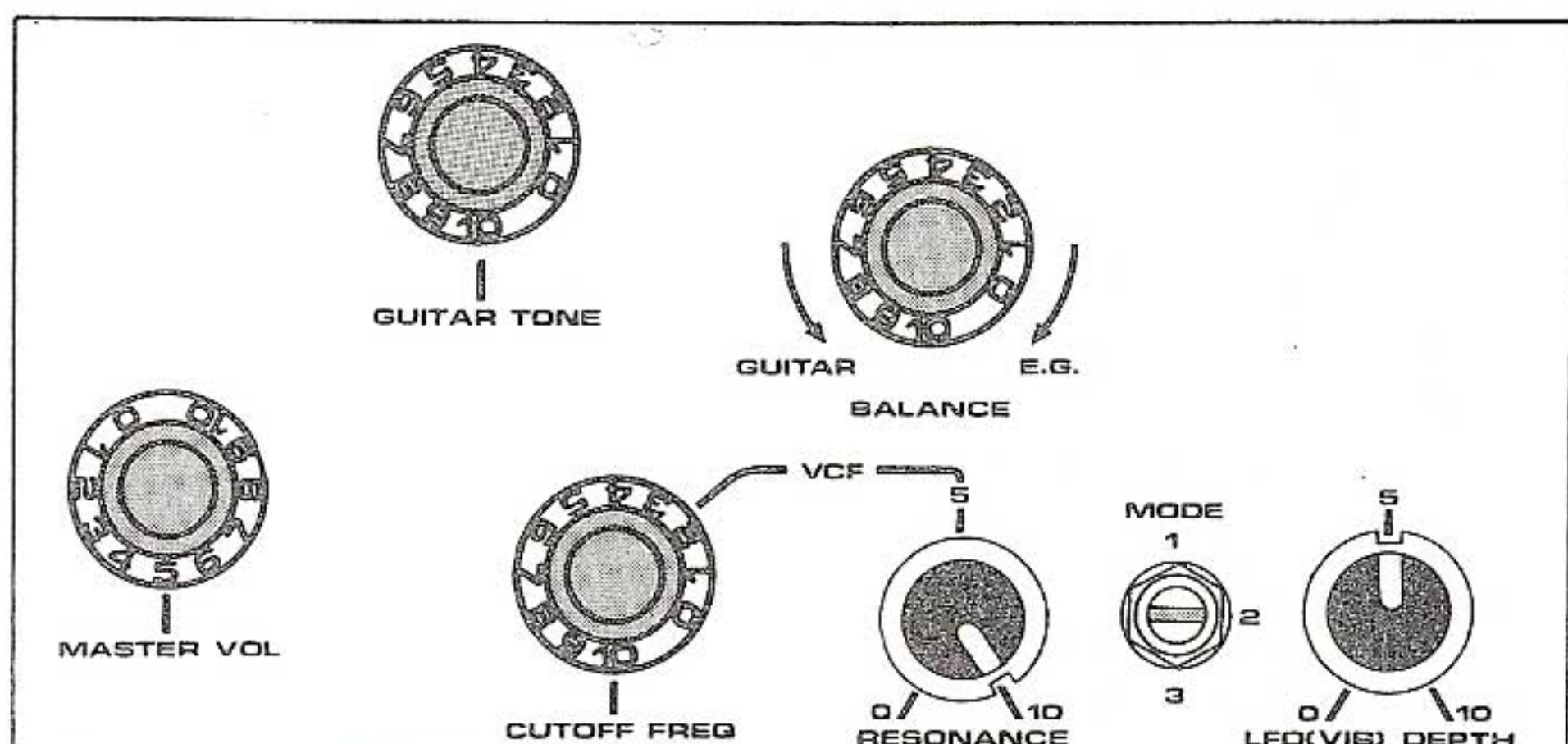
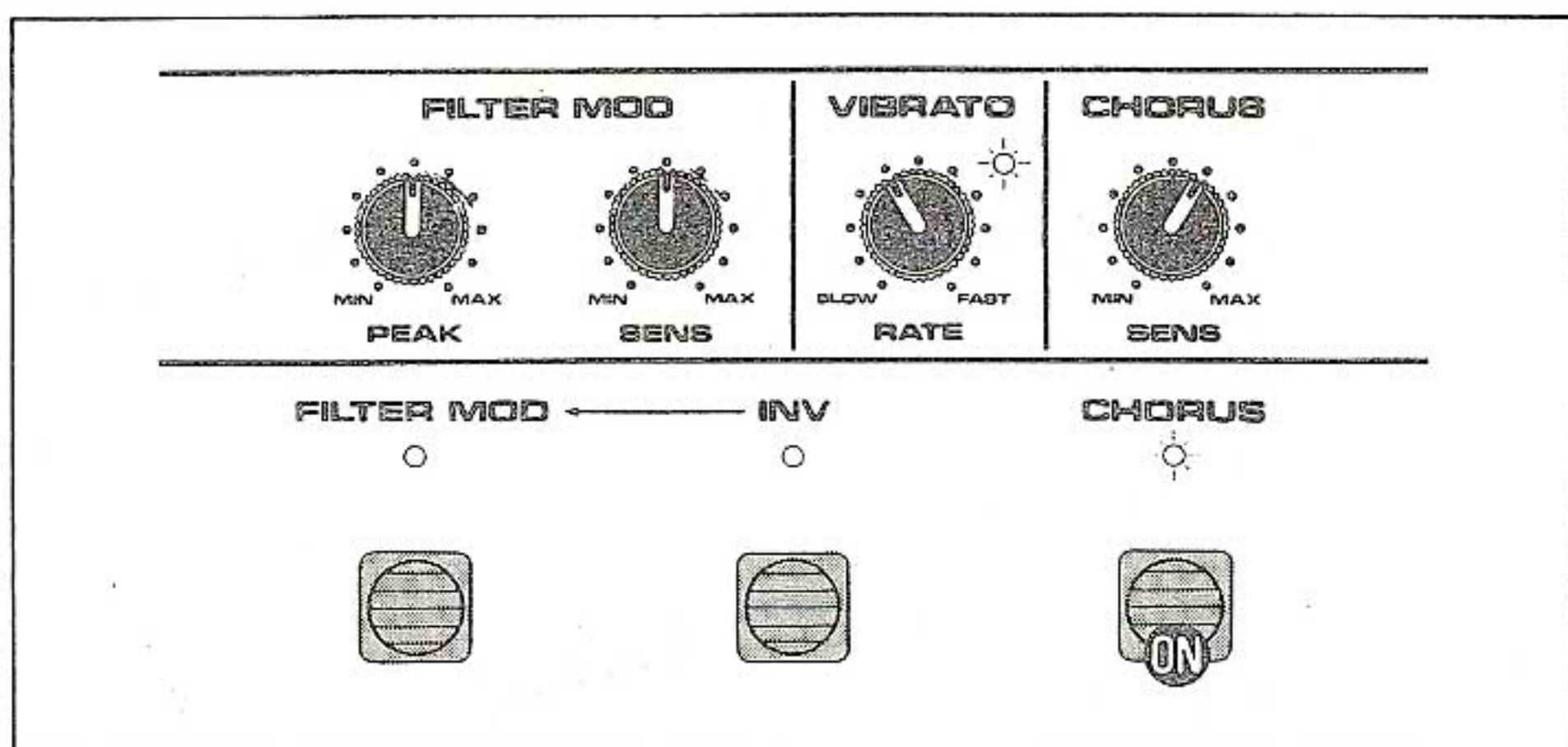

● Electric piano

▼GR-100

*Damping effect with the left hand

▼GUITAR

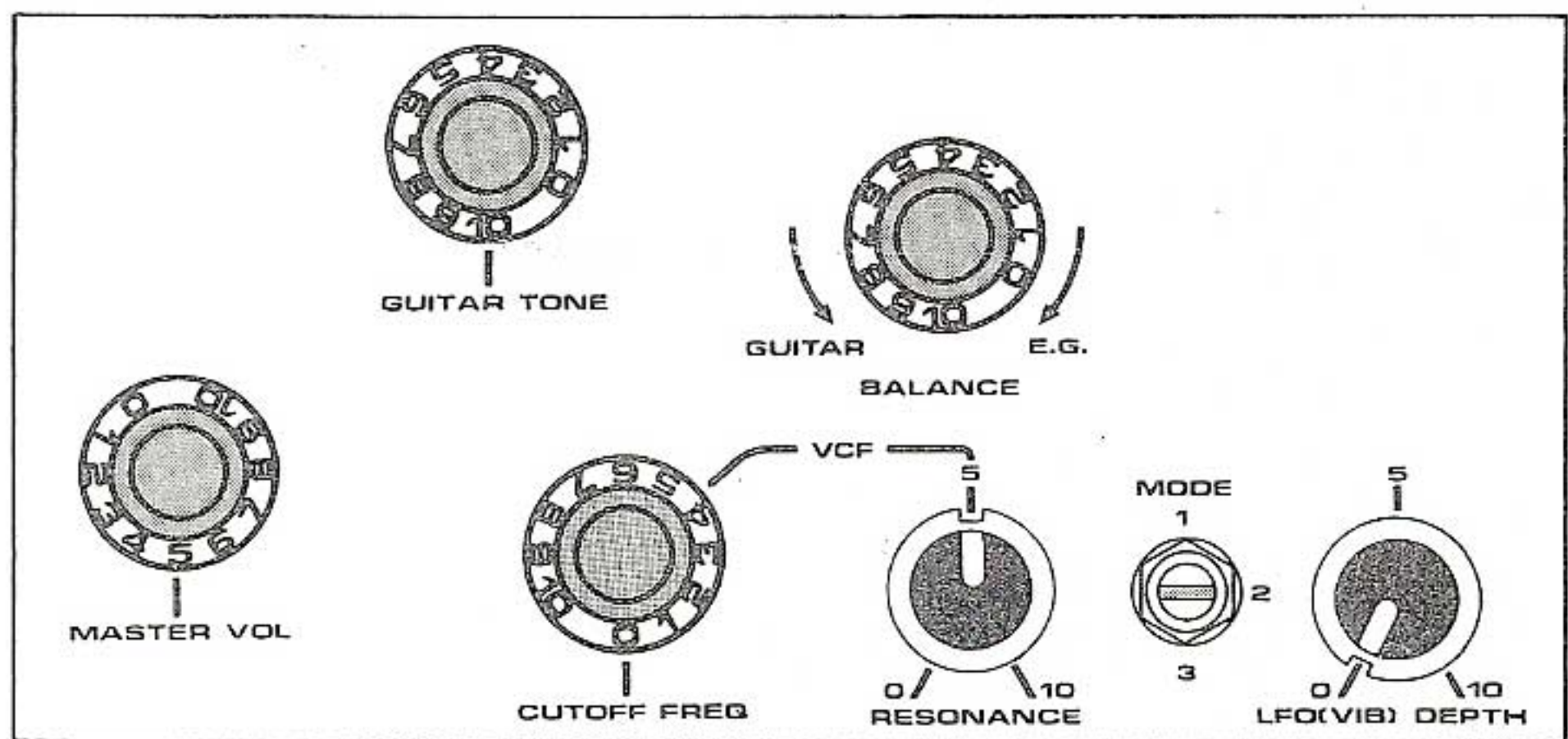
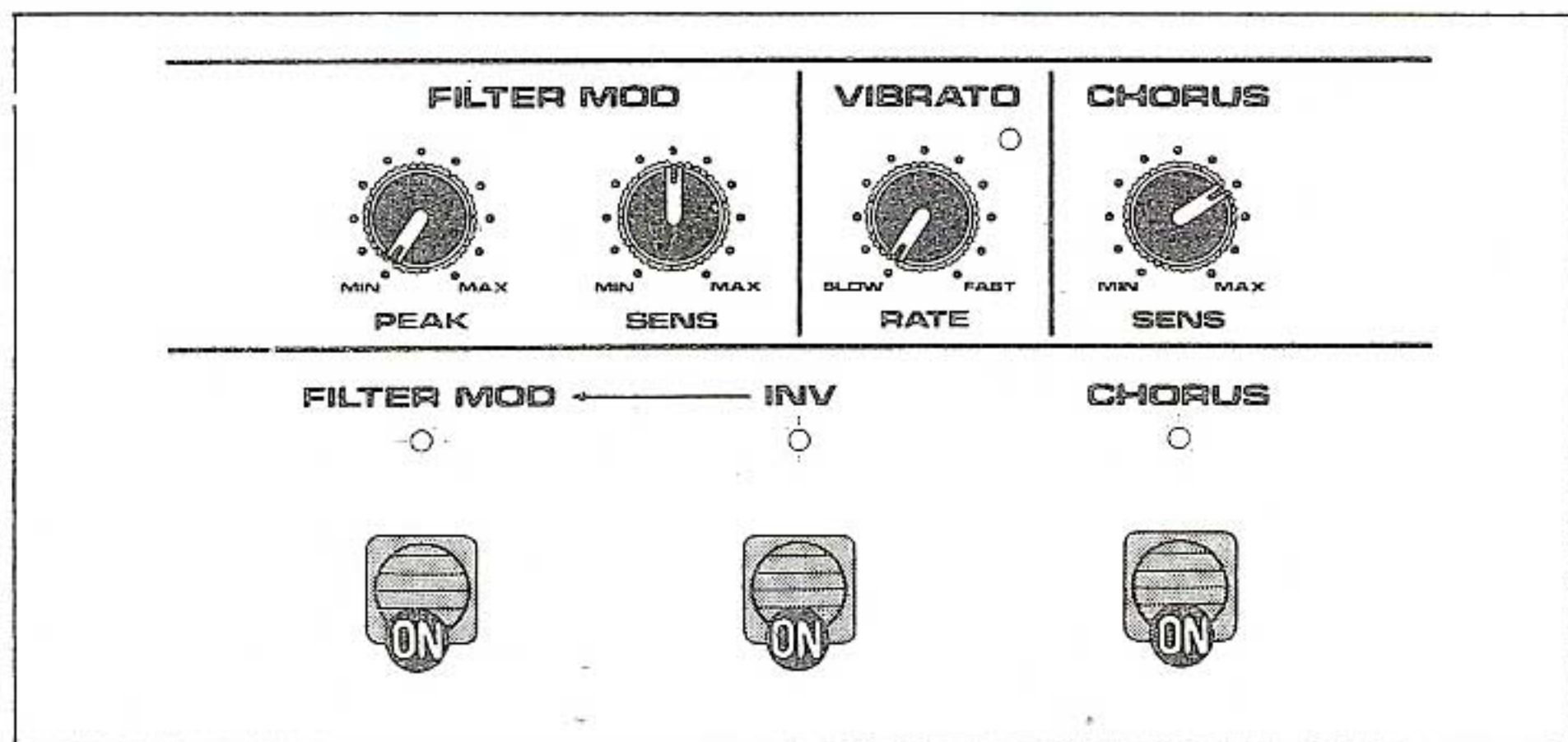

● Funky cutting

▼GR-100

*16 beats using mute

▼GUITAR

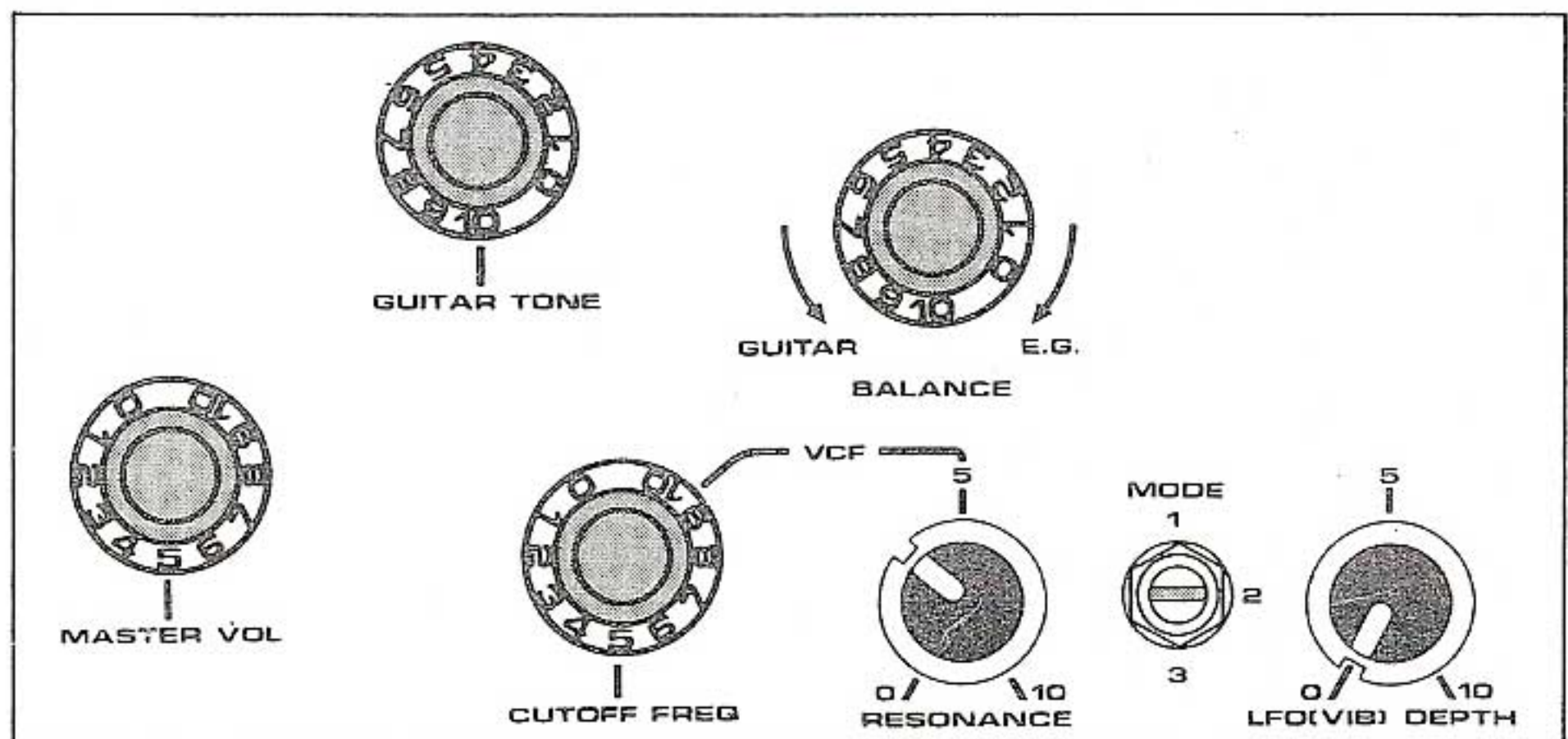
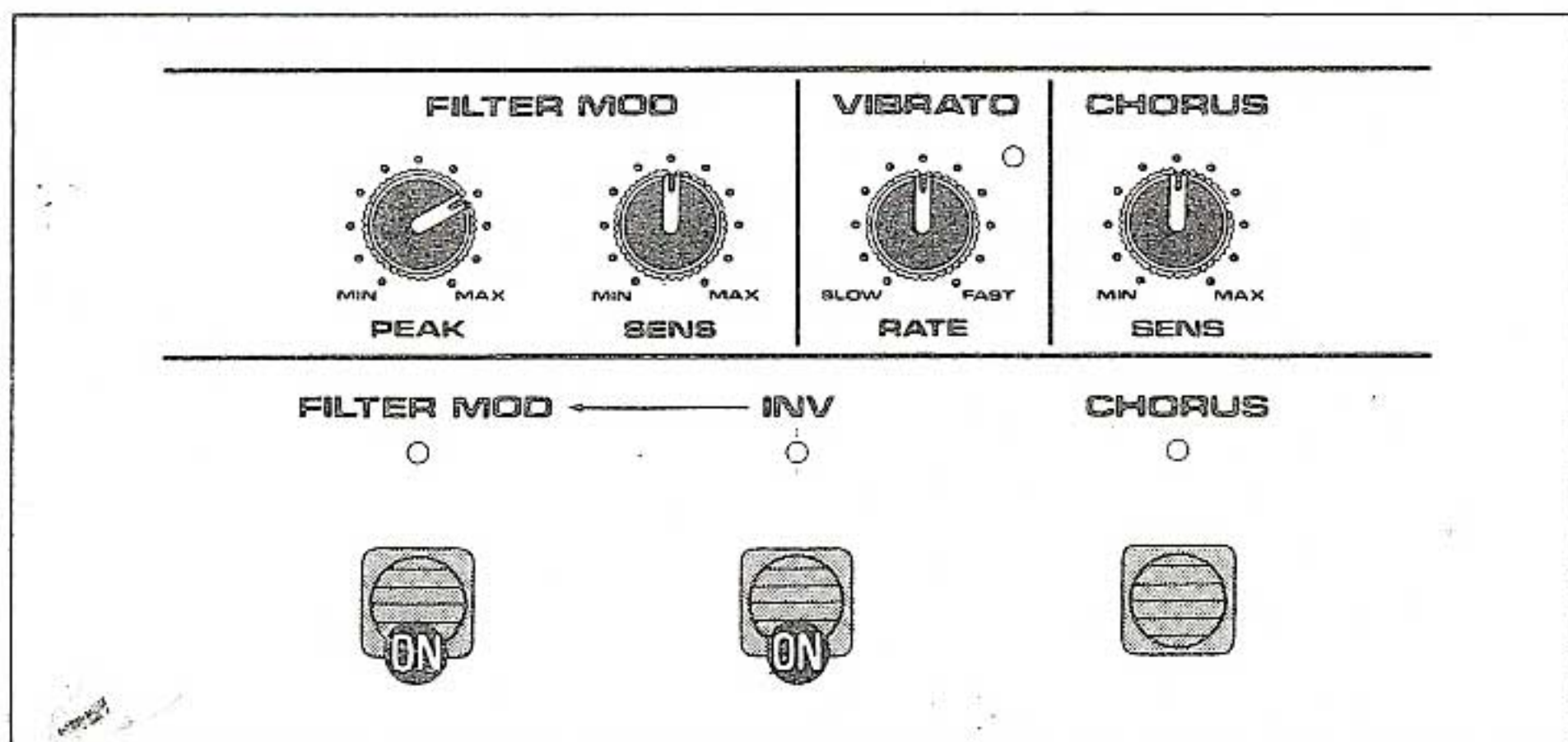

● Steve Lucassar style (from the album "EM & F")

▼GR-100

▼GUITAR

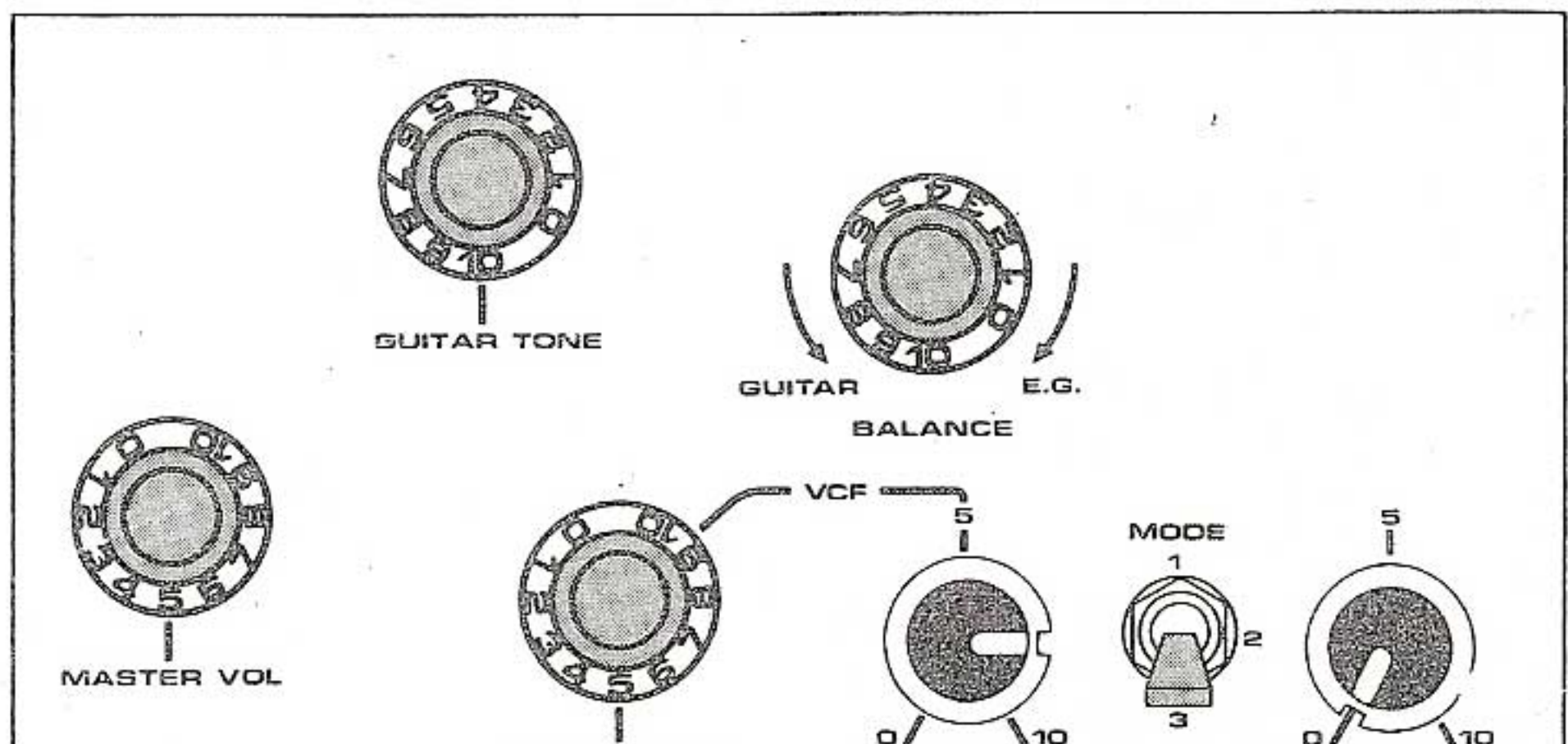
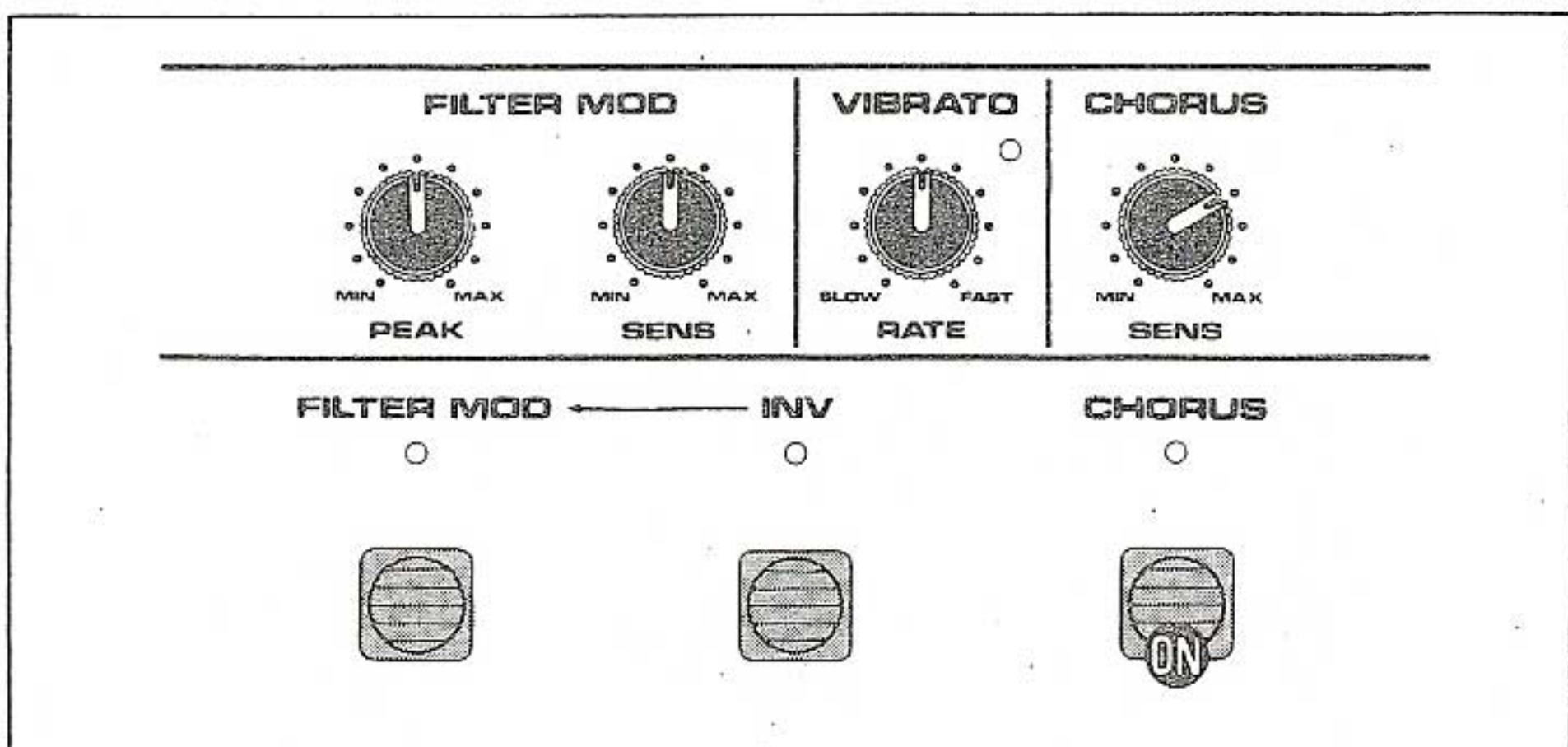

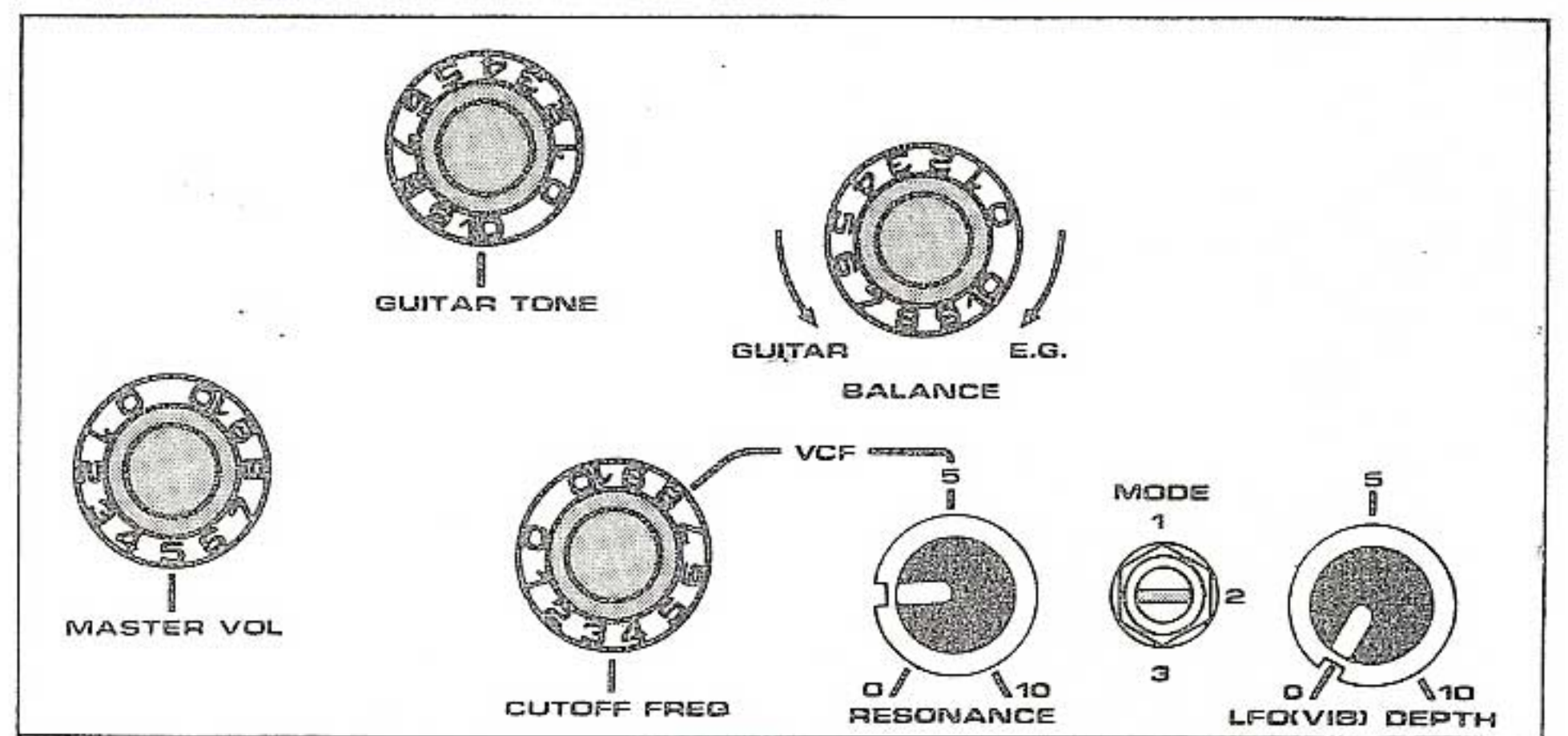
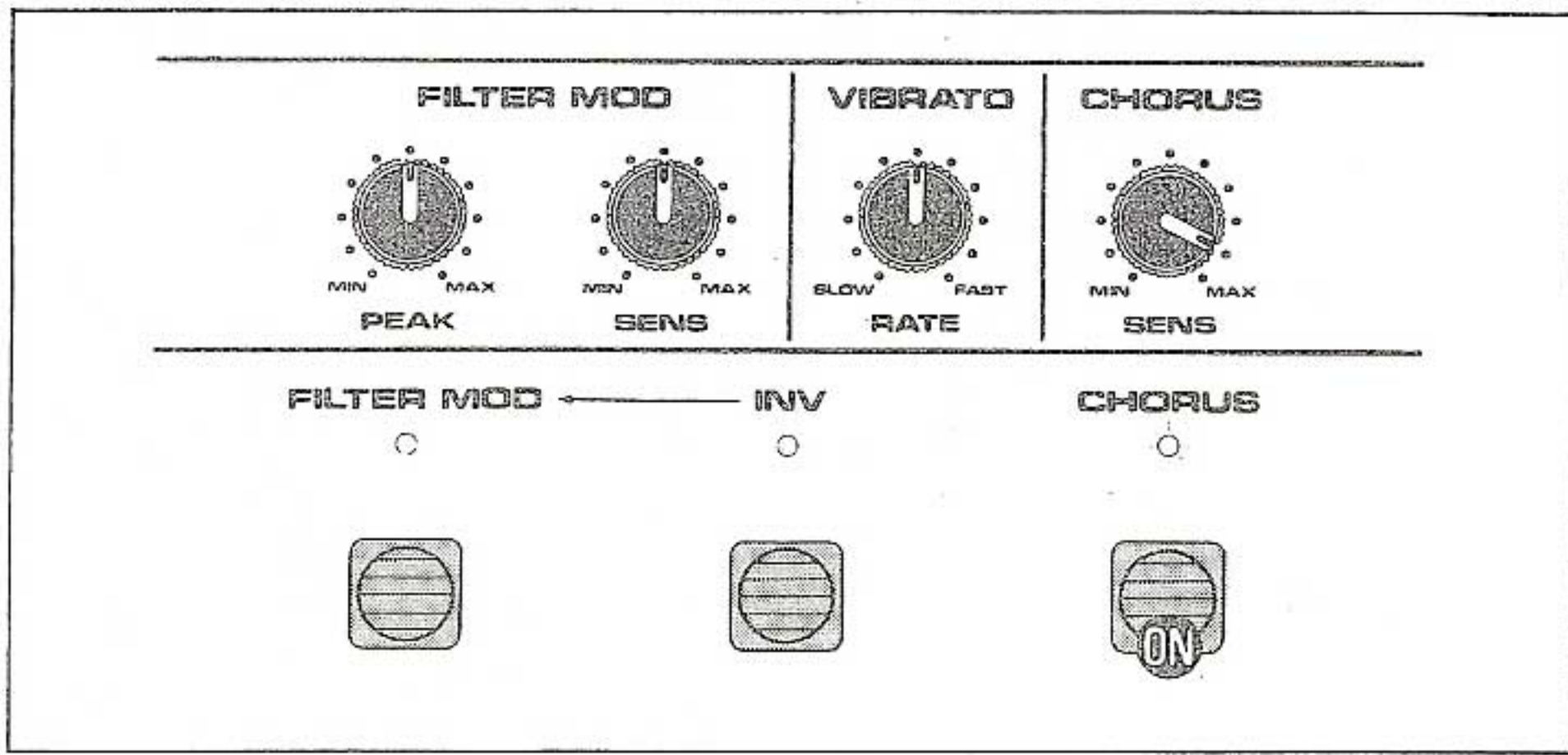

Sample sounds which can only be produced by guitar control *All foot switches on the unit side must be OFF

Jeff Beck style

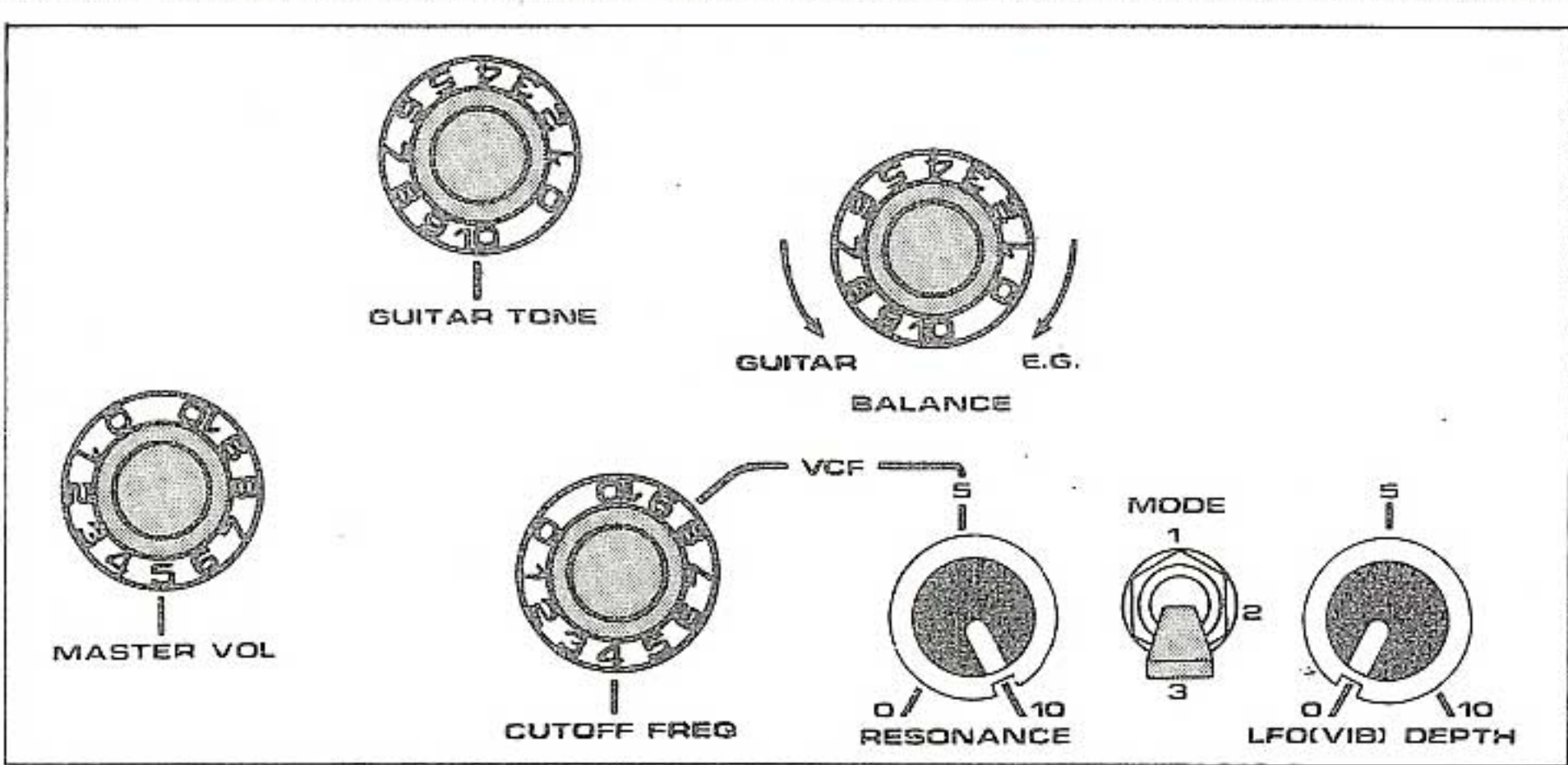

Larry Carlton style

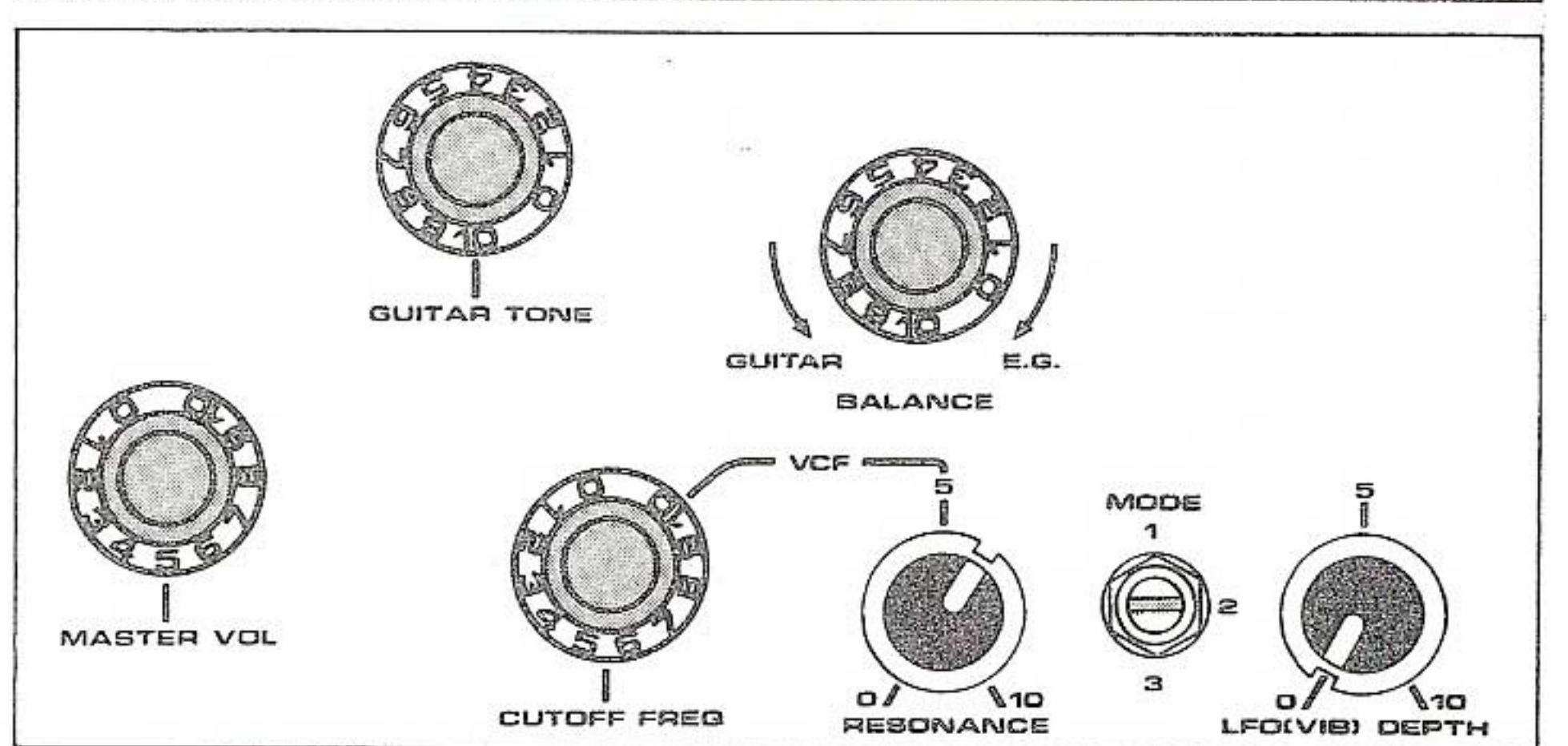

West Coast & Southern Rock

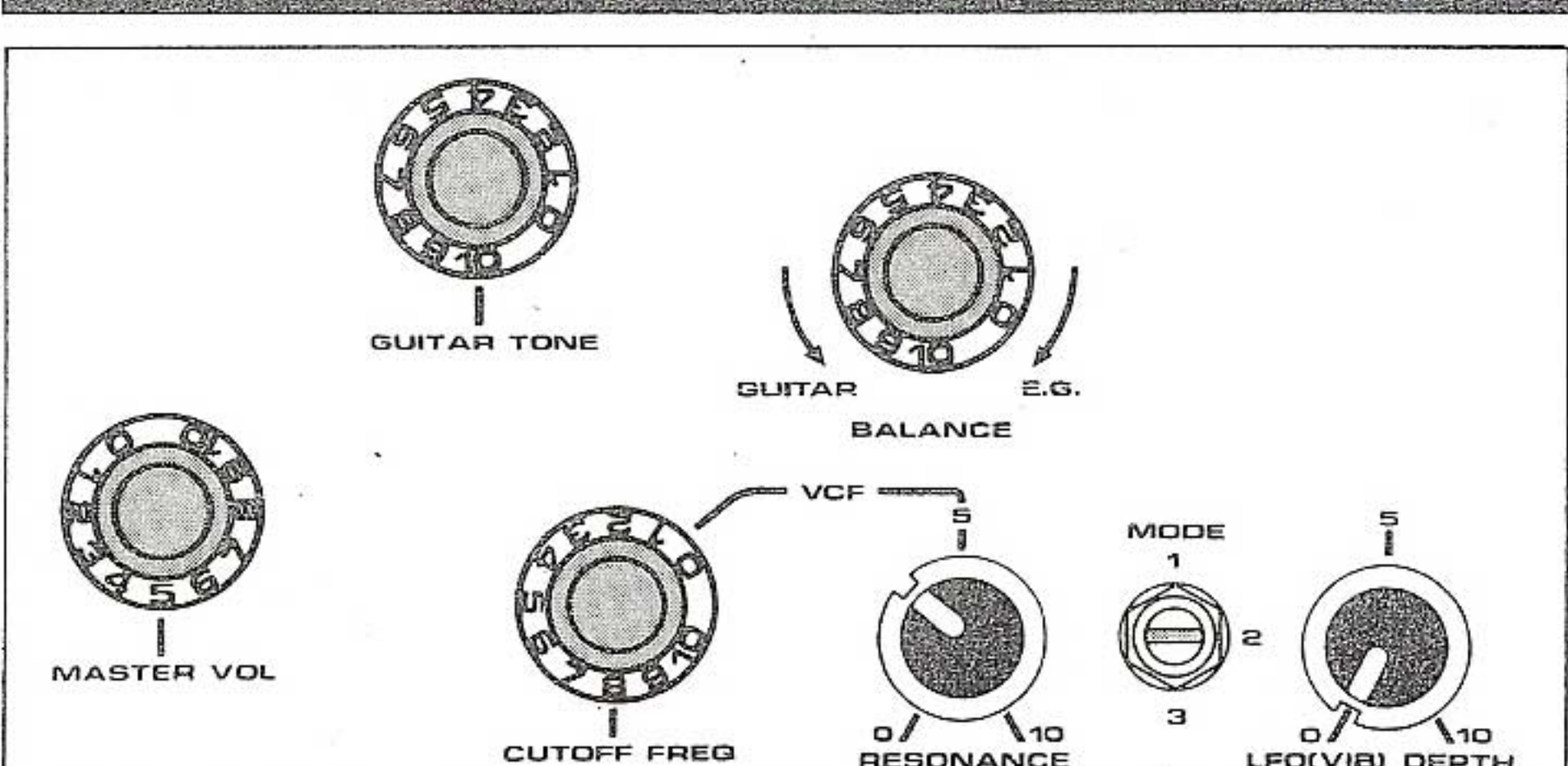

Hard Rock I

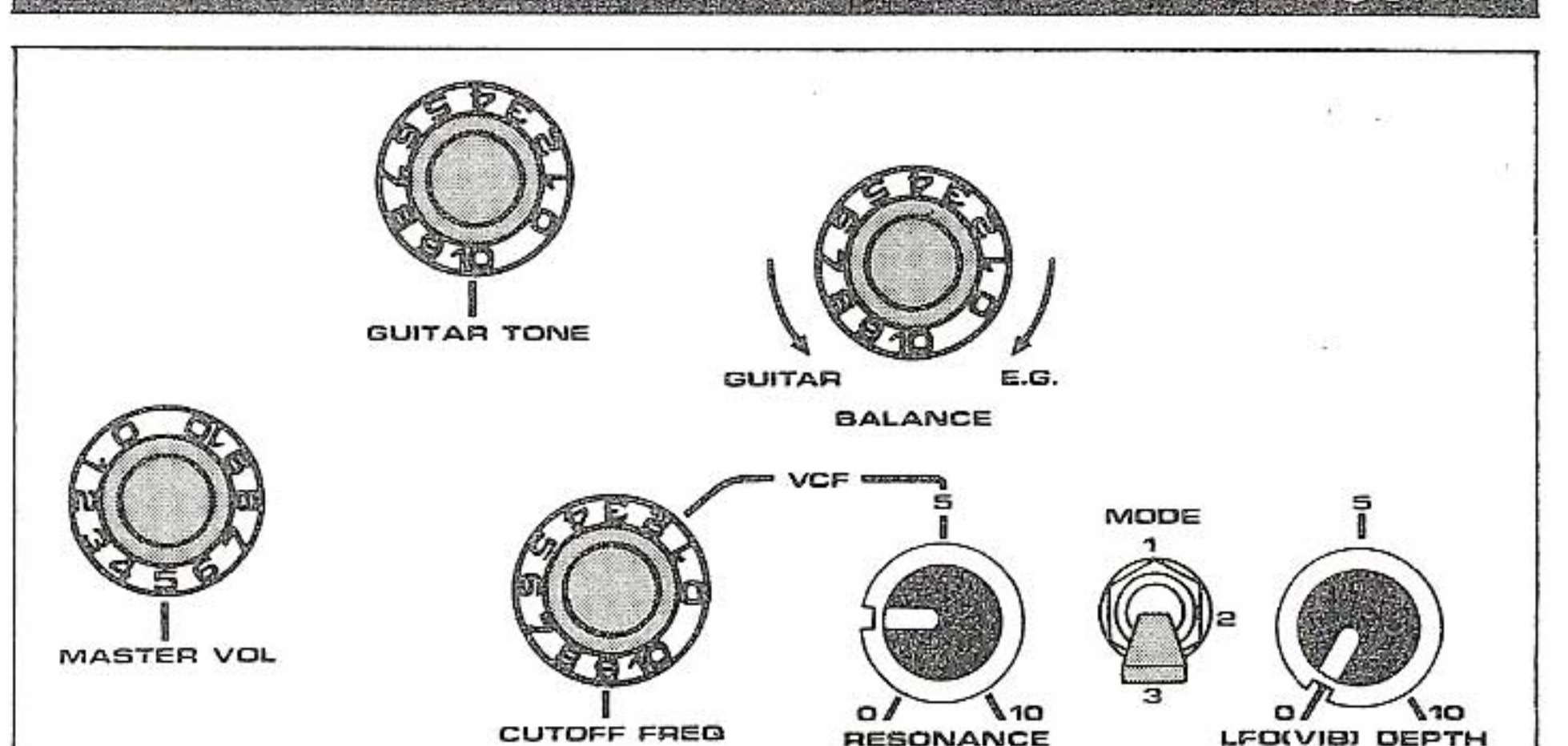

Hard Rock II

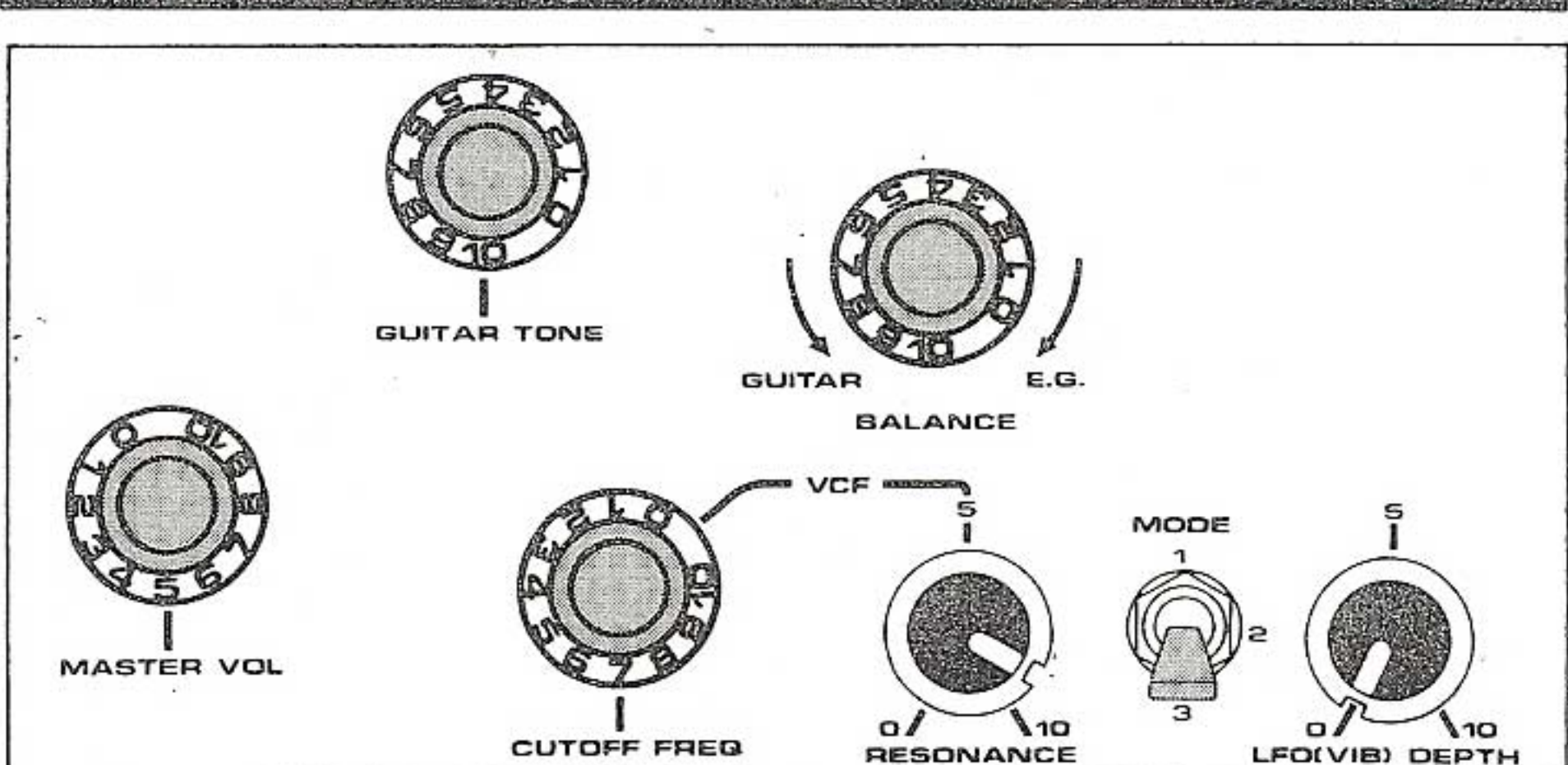

* The sound will vary according to how the strings are picked, and the type of amplifier in use, so control adjustment should be done by ear.

In order to obtain the best sound from the GR-100, please use a reproduction system with a flat frequency response (see Figure).
When connected to the AUX terminal of an audio system, although the output may be low, the GR-100 can provide stereo sound.

