

CV-13



EXPANDED BUS CONVERTER AND CONTROL VOLTAGE INTERFACE OWNER'S MANUAL

INTRODUCTION:

Congratulations on your purchase of the **CV-13** Expanded Bus Converter.

The **CV-13** combines the technology found in the Roland **BC-13** bus converter with a control voltage interface designed especially for the Roland **VG-99** and **FC-300**.

Like a **BC-13** Bus Converter, the **CV-13** can convert the vintage 24-pin style signals into modern, 13-pin control signals, enabling the

vintage guitar synth enthusiast access to the latest in guitar technology.

Your **CV-13** has been hand-built and hand-wired using quality components for reliable operation and is backed by a one-year parts and labor warranty.

Please read this owner's manual carefully before using the **CV-13**.

HOW THE CV-13 WORKS

The **CV-13** has two sections: string signal converters for the hex pickup, and a control voltage converters for the various control voltages generated in a vintage Roland guitar synthesizer controller.

The string signal converters for the **CV-13** have been optimized to work best with the sensitivities of the **Roland VG-99** guitar synthesizer, and are slightly different in design from the **BC-13/BX-13** series.

The control voltage section of the **CV-13** consists of six different voltage dividers with buffer circuits for each divider. There are on/off (mute) switches for the GK-VOL (synthesizer volume), Filter (CV #1) and Resonance (CV #2) control voltages. The **CV-13** was designed to work with a variety of controllers. If you are using a Roland controller, you may want to use the Filter (CV #1), Resonance (CV #2), Mod (CV#4) and Balance output to duplicate the range of controls on your guitar. With an Ibanez IMG2010, you could choose to use the virtual whammy bar outputs.

The **CV-13** has been designed especially for the **Roland VG-99** and **FC-300** combination. Using the EV-5 expression pedal jacks, this arrangement allows for four control voltage inputs, one on the **VG-99** and three on the **FC-300**. Check online (www.gr300.com) for examples and patching examples using the **Roland VG-99** and **FC-300 Roland**.

For the creative guitarist, there are lots of options. However, this can also lead to some confusion. After hooking the **CV-13** up to the **Roland VG-99** and **FC-300** combination, the **Roland VG-99** will need to be programmed to respond to control voltages from the **CV-13**. The online (www.gr300.com) examples can be helpful here as well. It is recommended that you maintain the same configuration to simply programming.

Also, it is important to properly calibrate the **CV-13**. The **CV-13** ships calibrated to work with the **Ibanez IMG2010**, since it has the most control voltage options. It is easy to adjust the calibration on the **CV-13**, and once set, it will not need to be changed, unless you switch to a different type of controller. For example, a **Roland G-707** will respond differently from a **Roland G-303**. Calibrating the **CV-13** is similar to adjusting the trimmer controls found inside every vintage guitar synthesizer, except you can use the display screen of the **VG-99** to make your adjustments as precise as possible.

IMPORTANT NOTES

- When connecting a guitar and synthesizer to the **CV-13**, be sure that power to the synthesizer is switched off.
- The 13-pin connector used with the **CV-13** is locking style, and therefore cables cannot be disconnected unless the locking pin is released.

REAR PANEL DESCRIPTION

- 1. 24-Pin GR Input Connector:** Input for 24-pin style G-Series guitar cable.
- 2. 13-Pin GK Output Connector:** The modern, 13-pin synthesizer output connector.
- 3. Gtr Volume:** This input allows a Roland EV-5 or EV-5 compatible pedal to vary the output of the standard (humbucker) output from the guitar.
- 4. Pin 9 to Ground Switch:** This switch connects Pin 9 to chassis ground. Pin 9 was not used in the Roland GK-2 and GK-2A pickups. The Roland VG-88, which can exhibit a ground loop (hum) in some configurations, internally ties pin 9 to ground. Flipping this switch up may help to eliminate ground loops in multiple synthesizer systems. The Roland GK-3 now uses Pin 9 to sense the position of the Gtr/Gtr+Synth/Synth output switch. You can leave this switch in the down (off) position if you are not experiencing any problems.

FOOTSWITCH CONTROL DESCRIPTION

- 1. Synth Switch:** This switch turns on and off the output level for the GK-VOL. The level for GK-VOL is controlled by both the MASTER volume guitar control on the guitar, and the BALANCE control. The associated RED LED will glow when the synth output is on.
- 2. Filter (CV #1) Switch:** This switch turns on and off the output level for the Filter (CV #1) control on the guitar. The associated GREEN LED will glow when the Filter (CV #1) output is on.
- 3. Resonance (CV #2) Switch:** This switch turns on and off the output level for the Resonance (CV #2) control on the guitar. The associated RED LED will glow when the Resonance (CV #2) output is on.
- 4. Guitar Volume:** This switch turns on and off the output of the standard (humbucker) guitar sound sent to the guitar synthesizer.

TOP PANEL EV-5 OUTPUT DESCRIPTIONS

- 1. CTL LO (CV#3):** This 1/4" TRS jack outputs a EV-5 type control voltage that is generated when the virtual whammy bar on an Ibanez IMG2010 is pressed down.
- 2. MOD (CV#4):** This 1/4" TRS jack outputs a EV-5 type control voltage that is generated when pressing on the touch pads of a vintage Roland G-202/303/505/707/808 controller, or when turning the *CTL Change* knob on an Ibanez IMG2010. The amount of voltage generated depends on the setting of the Modulation/LFO (CV #4) knob on the guitar.
- 3. Filter (CV #1):** This 1/4" TRS jack outputs a EV-5 type control voltage that is generated when turning the Filter (CV #1) knob on a vintage Roland G-202/303/505/707/808, or when turning the *Sensitivity* knob on an Ibanez IMG2010.
- 4. Resonance (CV #2):** This 1/4" TRS jack outputs a EV-5 type control voltage that is generated when turning the Resonance (CV #2) knob on a vintage Roland G-202/303/505/707/808, or when turning the *Velocity* knob on an Ibanez IMG2010.
- 5. Bal/CTL HI:** This 1/4" TRS jack can output one of two different signals, either the **Balance** (Guitar Volume) voltage, or the voltage that is generated when the virtual whammy bar on an Ibanez IMG2010 is pulled up.
- 6. Select Switch:** This switch selects the output for the **Bal/CTL HI**. When the switch is down (towards the LEDs), the output voltage is the **Balance** (Guitar Volume). When the switch is up (towards the rear of the **CV-13**) the output is the control voltage that is generated when the virtual whammy bar on an Ibanez IMG2010 is pulled up.

Master Volume, Synth Volume and Guitar Volume

A vintage Roland guitar synthesizer generates three control voltages for volume: a Master Volume voltage, Synth Volume voltage and Guitar Volume voltage.

The Master volume voltage feeds the balance knob, which then outputs a blend of synthesizer volume and guitar volume. With the balance knob in the middle, the synthesizer volume is 50%, and the guitar volume is 50%. With the balance knob fully counterclockwise, the synthesizer volume is 0%, and the guitar volume is 100%. At fully clockwise, the synth is 100% and the guitar is 0%.

In the **CV-13** only two voltages are used: the synthesizer volume and the guitar volume. This is the same way the GR-300 works as well. Synthesizer volume is converted to the GK-VOL, and the Guitar volume is output on the **Bal/CTL HI** top panel output jack.

If you are not using the Balance control on the guitar, be sure to turn the Balance knob fully clockwise, so that the Master Volume control will generate the complete range of volume. If you have the Master Volume control on the guitar turned to maximum, but the Balance control fully counterclockwise, there may be no output from the attached 13-pin synthesizer.

Please see the following diagram:

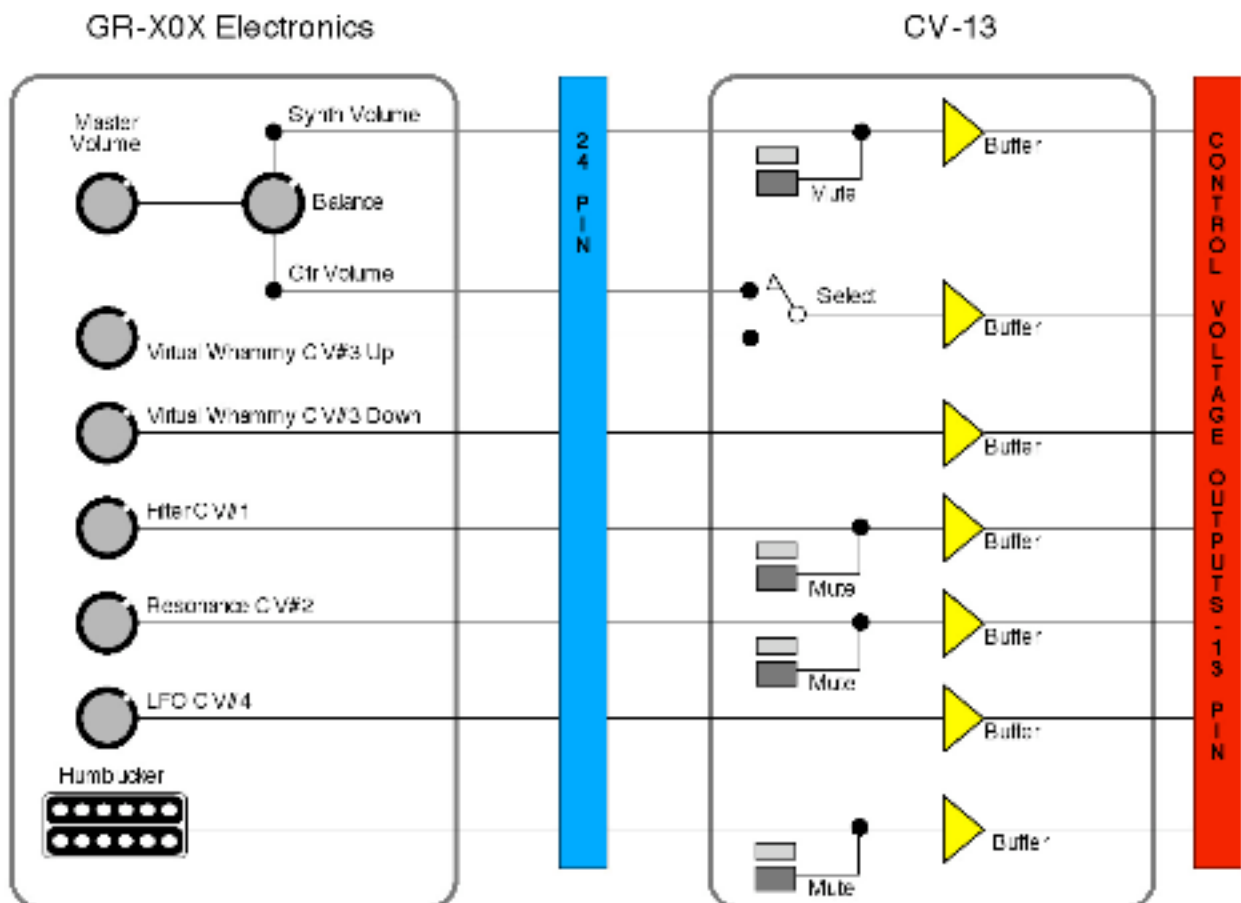

CALIBRATION

This is the procedure to precisely calibrate the control output of the CV-13. This example uses the patch "Pat's Rig" and demonstrates how to calibrate the output for the Filter (CV #1) knob. The same principles are used for the other output knobs and the virtual whammy bar as well.

Please check online (www.gr300.com) for a video demo of this calibration.

- 1. Hook up the 13 and 24 pin cables, and connect the Filter (CV #1) output of the CV-13 to the Expression Pedal input on the VG-99:** This will send control voltages generated by the Filter (CV #1) knob on the guitar to the VG-99's EV-5 Expression pedal input. This is the input on the VG-99 itself, not on the FC-300.
- 2. Open the CV-13:** First remove the two #8 screws on the top of the CV-13, then remove the four screws on the bottom of the unit. The top panel lifts away from the bottom panel and wood sides.
- 3. On the VG-99 press COSM Guitar A Edit:** This should take you to the first edit page of COSM Guitar A.
- 4. Press the Page Right Button Twice:** You should now be on page 3, and you can see the CUTOFF FREQ parameter.
- 5. Turn the Filter (CV #1) Control on the Guitar:** Slowly turn the Filter (CV #1) Control on the guitar and you should see the CUTOFF FREQ change in the display of the VG-99. The Filter (CV #1) Control is also called the Sensitivity in the Ibanez IMG2010 manual. Turn the Filter (CV #1) Control fully clockwise. The level should be close to 100.
- 6. Adjust the Filter (CV #1) Trimmer:** Refer to the diagram on the opposite page. The Filter (CV #1) trimmer is on the upper left hand corner of the circuit board. The arrows indicate what direction to turn the trimmer to increase output. Using the supplied 2.4 mm screwdriver, gently turn the trimmer until the CUTOFF FREQ display switches from 99 to 100.
- 7. Turn the Filter (CV #1) Control on the Guitar:** You should see the CUTOFF FREQ reach 100 just as the Filter (CV #1) Control on the Guitar reaches the full clockwise travel.
- 8. Repeat for Other Control Voltages:** Repeat for the other controls. You can check the assign pages in the VG-99 to see how the expression pedals are assigned.
- 9. Attached the Top Panel to the Bottom Panel and Side Panels:** First reinstall the two #8 screws on the top panel, but do not tighten completely. Install the bottom four screws, and finally tighten the top two screws. Do not over tighten.

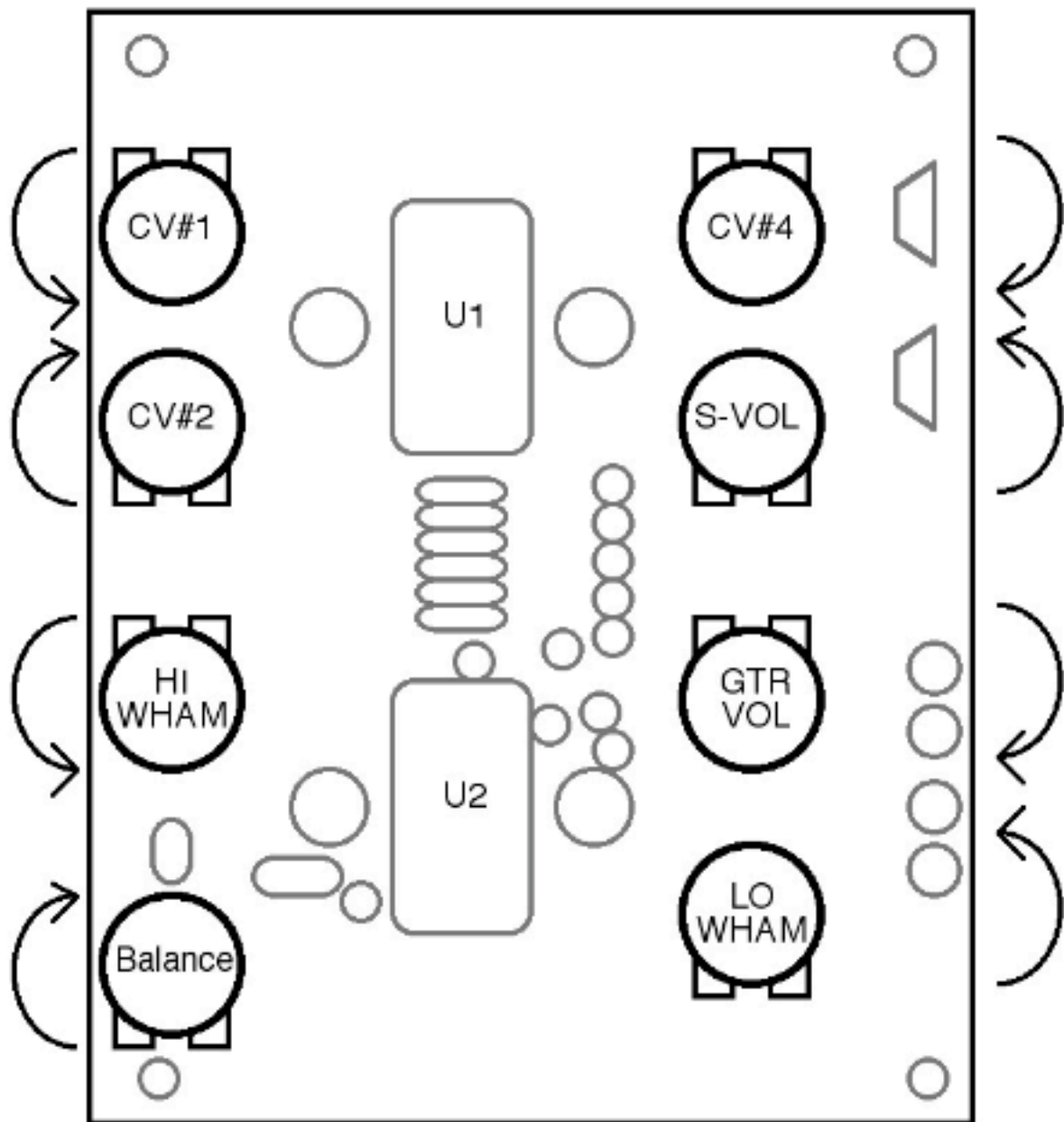

The arrows show the direction to turn the trimmers to increase control voltage output.

SPECIFICATIONS

CV-13 Bus Converter:

- **Connectors (rear panel):** One 24-pin input connector, one 13-pin output connector, one 1/4" standard phone jack for EV-5 pedal input (guitar volume) .
- **Connectors (top panel):** five 1/4" TRS phone jacks outputting control voltages in Roland EV-5 format

- **Dimensions:** 11 (W) x 8 1/2 (D) x 3 1/2 (H) inches
- **Weight:** 3 lbs 12 oz

v1.0 03.14.2008
© copyright March 2008
www.gr300.com

ROLAND IBANEZ TERMINOLOGY

This manual uses the terminology associated with the Roland GR-300 and the Roland G-202/G-303/G-505 and G-808 guitars. This is the most popular vintage Roland guitar synthesizer system. In this system, the first control knob on the guitar is for the cutoff frequency of the GR-300's filter, the second knob controls the GR-300's resonance, and the third knob is for LFO (Vibrato Depth). In the Roland service manuals these are more generically referred to as CV #1, CV#2 and CV#4. CV#3 was only used on the Ibanez IMG2010, and it is assigned to Pitch, controlled by the virtual whammy bar.

The Roland G-707/GR-700 combination worked a bit differently, with first control knob on the G-707 guitar adjusting the filter when the GR-700 is in EDIT mode, and second knob (resonance) used as a general value knob. The LFO knob still controlled LFO (Vibrato Depth).

The Ibanez IMG2010 was designed to specifically as a MIDI controller with the Ibanez MC1, and so the first control knob on the IMG2010 (cutoff frequency, CV#1) is called *sensitivity*, and the second knob (resonance, CV#2) is assigned to *velocity*, and the last knob is *CTL Change*, which was usually assigned to vibrato.