

 **Roland**

Bass Guitar Controller G-77

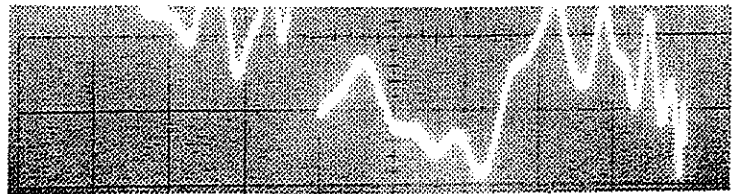

INSTRUCTIONS

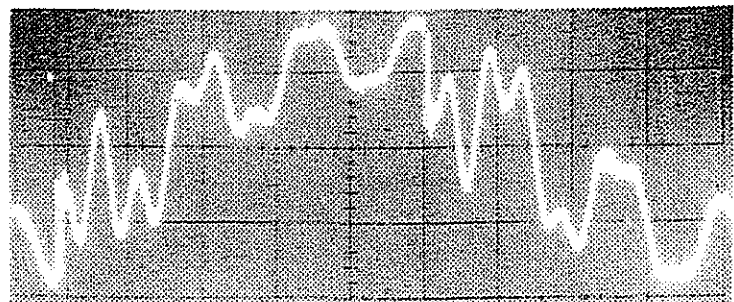
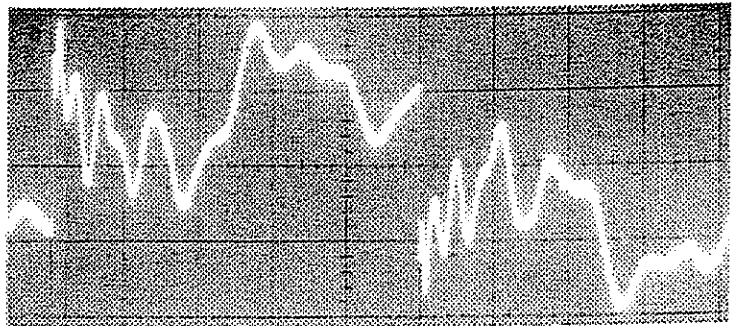

Bass Guitar Controller G-77

INSTRUCTIONS

FEATURES

The Roland G-77 is, with its unique stabilizer and the divided pickups (for controlling the synthesizer), a breakthrough of a bass guitar controller.

Also, two sets of original hum bucket pickups mounted, the G-77 allows extremely strong bass sound when used as an electric bass guitar.

* When the G-77 is used as an electric bass guitar, the following switches and knobs are not relevant.

- Balance Knob
- Cutoff Frequency Knob
- Edit Knob
- LFO Modulation Knob
- Mode Switch
- Touch Plates

CONNECTION

The G-77 is designed to use with the GR-77B only. However it can work with GR-33B with some compromise. (No other synthesizers can be used with G-77.)

See the owner's manual of the GR-77B or GR-33B for detailed setup procedure.

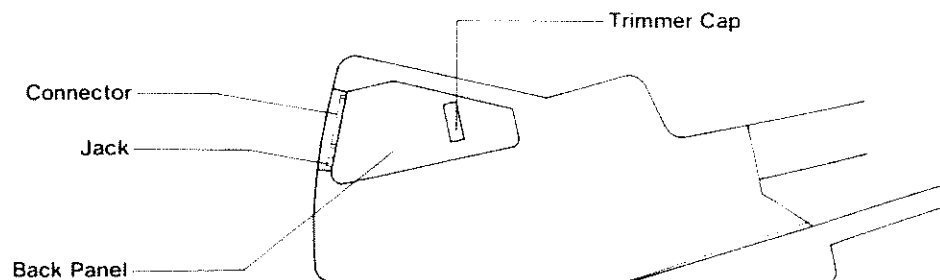
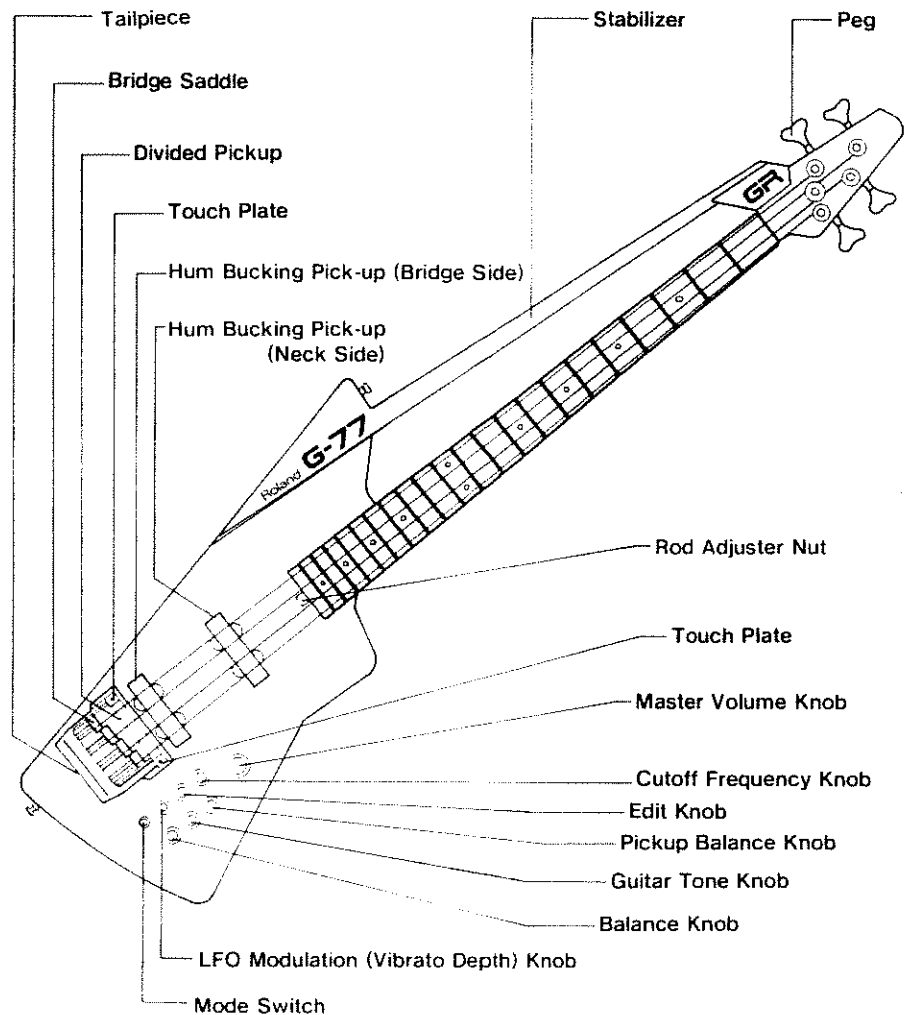

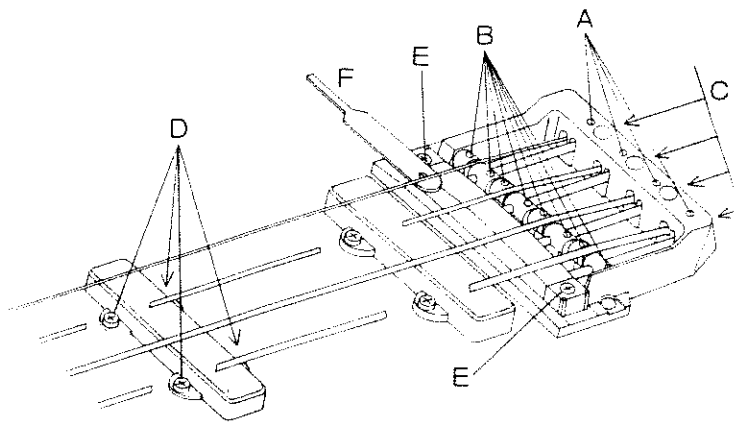

ADJUSTMENT

The following adjustments may be necessary from time to time. Specially when you have replaced with the string of a different gauge, all the adjustments are required.

1st string : 2.5mm
 2nd string : 2.6mm
 3rd string : 2.8mm
 4th string : 3.0mm

a. Adjusting the warp of neck

By rotating the Rod Adjuster Nut with the supplied wrench, adjust the warp of the neck. Turning the wrench clockwise will make convex bend and the counter-clockwise the other way round.

- Concave bow

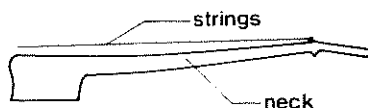

- Convex bend

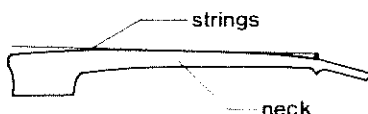

b. Adjusting the string height

- 1 Loosen the small screws A on the tailpiece with the supplied wrench.
- 2 By rotating the small screws B, adjust the height of the bridge saddle.

The following is the height of the strings set at the factory. The distances are taken between the bottom of a string and the 12th fret with open string.

- 3 When you have adjusted all the strings, tighten the small screws A.

NOTE

If a string's height is too low, it tends to touch the frets causing unstable pitch.

c. Octave Adjustment

- 1 Loosen the small screws A on the tailpiece.
- 2 Loosen the cross-head screws C with a screw driver and move the bridge saddle so that the 12th fret pitch is exactly an octave higher than that of the open string.

*For more accurate tuning, use the tuner (e.g. BOSS TU-12, TU-12H, etc.)

- 3 When adjustment is completed, tighten the screws A.

d. Adjusting the height of the Hum Bucking Pickups (pickups for normal bass sound)

By rotating the cross-head screws D that hold the hum bucking pickups, adjust the height.

*The height of the pickup (= distance between the bottom of a string and the pickup) is initially set at the factory, at 4mm on the neck side and 2mm on the other side.

e. Adjusting the height of the divided pickup

This is the most important adjustment of all. So do it with extreme accuracy.

Rotate the cross-head screws E that hold the divided pickup with a screw driver so that the distance from the bottom of the 1st and the 4th strings to the divided pickup is about 1mm.

*Use the supplied gap gauge F that is exactly 1mm high to make a distance of 1mm.

f. Adjusting the output level of the guitar

If your G-77 is still in unsatisfactory condition even after all "a" to "e" adjustments are done, adjust the output level of the guitar.

*How to adjust the output level of the guitar is fully explained in the owner's manual of the GR-77B.

Setup with the GR-33B

The G-77 is specially designed for the GR-77B. Setting up the G-77 with the GR-33B will cause the following problems.

- 1 The reaction of the GR-33B will be unstable.
- 2 The GR-33B's output level will be somewhat lowered.

Roland®

10525

UPC

10525

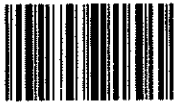

:490:

Roland®